

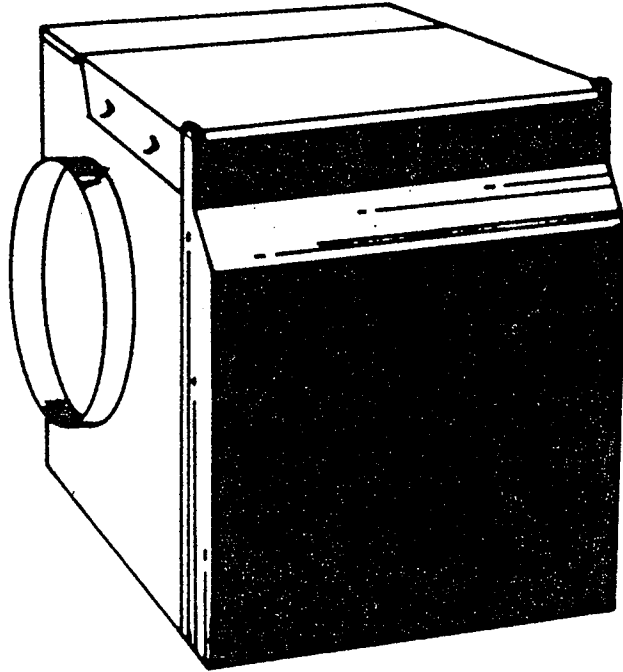

# *FreshMist*90

## OWNER'S MANUAL



## FM 90 CENTRAL SYSTEM HUMIDIFIER

**Installation and Service Instructions**

**Thank You!**

Thank You for selecting a FreshMist 90 Humidifier.  
It will provide years of service if you give it a little care.

**READ AND SAVE THESE INSTRUCTIONS**

# Selecting A Location

Consider these points as you choose the location for your humidifier.

For best performance, locate the humidifier on the HOT air plenum (Fig. 1).

If furnace is equipped with air conditioning, humidifier should be mounted above or at slope side of "A" coil (Fig. 2).

Humidifier should be installed so that if the humidifier or any other connections should leak, the resulting flow of water will not cause damage. Under no condition is the manufacturer to be held liable for any water damage in connection with this humidifier. Never install humidifier in attic or crawl space where freezing may occur or leaking will cause water damage.

If holes between HOT air plenum and COLD air plenum must be located more than 36 inches apart (Fig. 1), standard 6 inch round pipe and fittings (not supplied) may be used.

If space is limited on the HOT air plenum, installation of the humidifier on the COLD air plenum is correct. The collar/damper is mounted on the HOT air plenum for COLD air plenum installation.

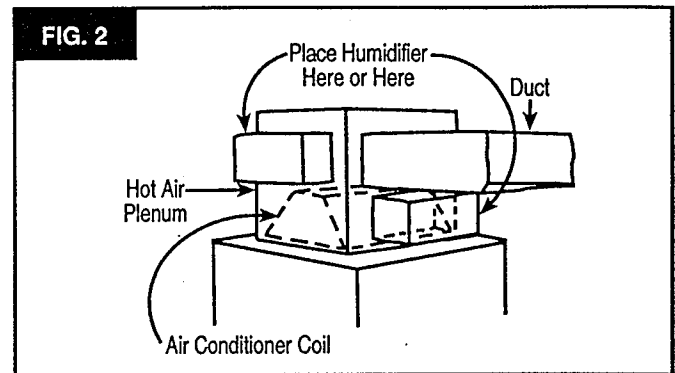
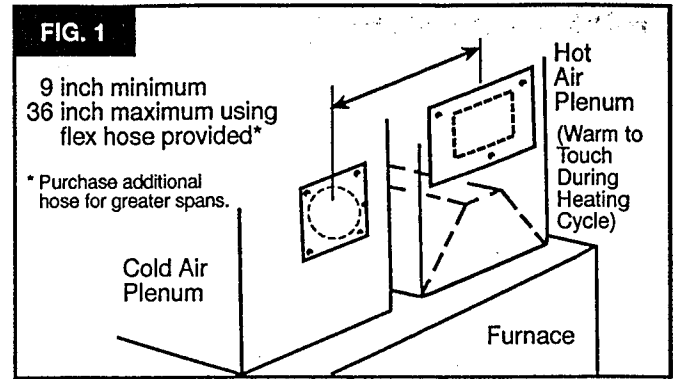

## inspection

This humidifier is assembled with the bypass duct on the left side (Fig. 3). This is suitable for installation as shown in Fig. 1. If this is suitable for your installation, remove parts as shown under **Disassembly**. Skip conversion steps 1, 2, 3, and 4. Start your installation with  5.

If you require the bypass duct on the right (Fig. 4), remove parts as shown under **Disassembly** and start with  1.

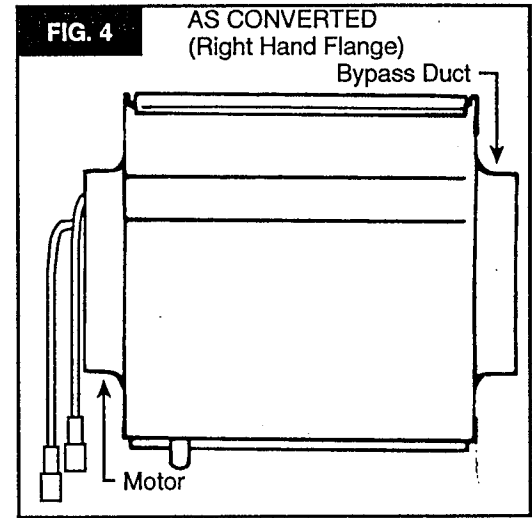
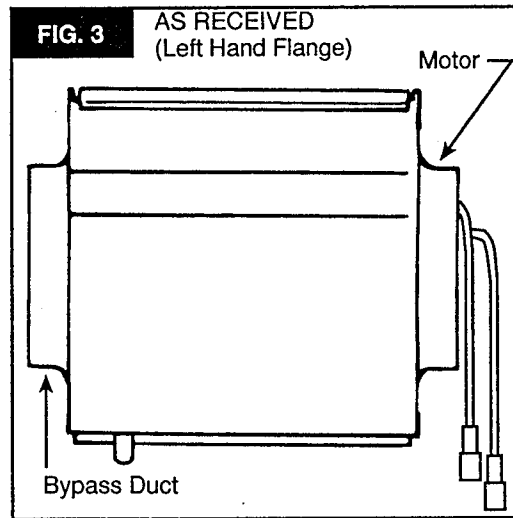

## disassembly

- Remove front cover. Lift top cover to lock position.
- Pull pivot pin and remove float assembly from valve.
- Lift out media wheel.
- Remove water reservoir.

## conversion — (If required — see "inspection" above)

- 1 Pull motor bracket and wire bearing support to remove from lances (Fig. 5).

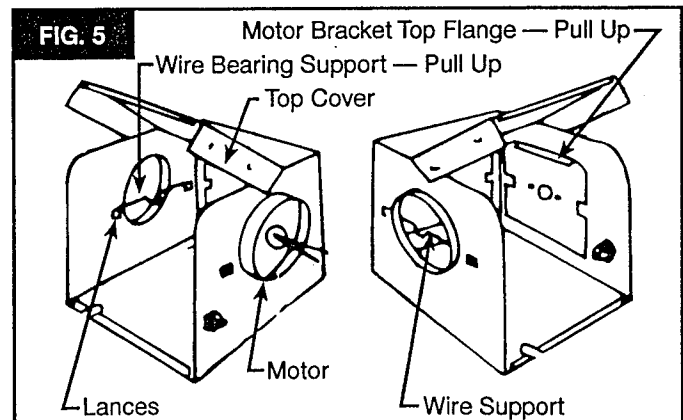

# contents

WARRANTY .....	2	UNDERSTANDING HUMIDITY .....	3	HUMIDISTAT .....	7
BEFORE YOU START		SELECTING A LOCATION .....	4	OPERATION .....	9
Rules for Safe Installation		INSPECTION .....	4	MAINTENANCE .....	9
and Operation .....	2	DISASSEMBLY .....	4	SERVICE HINTS .....	10
Tools and Materials Needed .....	2	INSTALLATION .....	6	REPAIR PARTS .....	11

## introduction

Please read the instructions before you use your humidifier. This will help you obtain the full value from the humidifier. It will also help you avoid any needless service cost, if the problem is something we cannot control and cannot cover in our Warranty.

### 90 DAY LIMITED WARRANTY

This product of The Field Controls Company is warranted to be free from defects in material and workmanship under normal use for 90 days from date of purchase. In the event of a malfunction or failure of this product, the purchaser should properly package the entire unit and ship it PREPAID with return address to the address listed below. At the time of request for warranty service, the purchaser must present proof of purchase documentation which includes the date of purchase (for example, a receipt or sales slip). If the malfunction or failure is a result of defects covered by this warranty, Field will, at its option, repair the product or replace it and return it to the purchaser.

This warranty is limited to the original retail purchaser and is not transferable. The warranty does not cover damage due to accidents, abuse, tampering or misuse, nor does it cover damage resulting from service by persons other than Field.

FIELD'S LIABILITY UNDER THIS WARRANTY IS LIMITED TO THE REPAIR OR REPLACEMENT OF A DEFECTIVE PRODUCT. FIELD SHALL NOT BE LIABLE FOR ANY INCIDENTAL OR CONSEQUENTIAL DAMAGES, WHETHER DIRECT OR INDIRECT.

THIS WARRANTY IS EXPRESSLY GRANTED IN LIEU OF ALL OTHER WARRANTIES EXCEPT IMPLIED WARRANTIES. ALL IMPLIED WARRANTIES INCLUDING, BUT NOT LIMITED TO, THE IMPLIED WARRANTIES OF MERCHANTABILITY AND FITNESS FOR A PARTICULAR PURPOSE ARE LIMITED IN DURATION TO THE PERIOD OF THIS EXPRESS WARRANTY.

Some states do not allow the exclusion or limitation of incidental or consequential damages, or limitations on how long an implied warranty lasts, so the above limitations or exclusions may not apply to you. This warranty gives you specific rights and you may also have other rights which vary from state to state.

In the event you have any questions concerning the use and care of your Field product or concerning service under this warranty or otherwise, please write: The Field Controls Co., 2308 Airport Rd., Kinston, N.C. 28501.

### DO-IT-YOURSELF CHECK LIST

If you feel the following operations are within your skills, you should have no difficulty installing this humidifier.

- Cutting and drilling sheet metal.
- Using hand tools: screwdriver, wrench, etc.
- Hooking up low voltage electrical connections.

You must realize that the wrong use of any tool can be dangerous. Be sure you know how to use the tools and equipment to avoid any possible hazards. You should understand electrical wiring.

Humidifier must never be installed in an attic or any other location where if the humidifier or any part of the system should leak, the resulting flow of water would cause damage.

## before you start

### RULES FOR SAFE INSTALLATION & OPERATION

1. Read these rules and the instructions carefully. Failure to follow the rules and instructions could cause bodily injury and/ or property damage.
2. Check your local building codes and utility standards. The installation must comply with their rules.
3. Always shut off the furnace blower before installing or servicing the humidifier.
4. Always wear safety glasses when installing or servicing the humidifier.
5. HUMIDIFIER MUST NOT BE INSTALLED IN AREA WHERE FREEZING IS POSSIBLE OR LEAKING WOULD CAUSE WATER DAMAGE.
6. Follow a regular service and maintenance schedule.
7. Always shut off electricity and water to the humidifier before servicing.
8. NEVER OIL ANY PART OF THE HUMIDIFIER.
9. When the furnace blower is used for air-conditioning, the humidifier damper should be closed, and the humidistat should be turned to the minimum humidity setting.
10. To prevent over humidification, humidifier must not be operated above humidistat high position or above the +20 position (whichever applies) except briefly to test operation after installation or servicing.

### TOOLS AND MATERIALS NEEDED

- Safety Glasses
- Straight edge ruler
- Pencil or grease pencil
- Hand drill or grounded electric drill
- Drill bits, 5/32", 1/8"
- Tin snips or metal cutting saw
- Screwdriver (flat point, medium size)
- File
- Level
- Hammer
- Small adjustable wrench
- Center punch

## UNDERSTANDING HUMIDITY

Humidity can be puzzling. It cannot be seen, heard, touched, smelled or tasted. Many people do not understand what a humidifier will or will not do.

Probably the best way to judge whether the humidity is too high, too low or about right is to watch your windows. If they are heavily fogged you most

likely have too much. If there is no moisture on them at all, especially in the corners, you have too little. (*NOTE: Moisture will not normally form on thermopane or when storm windows are used.*) If there is some moisture in the window corners and along the edges, the humidity is just about right. This is a good rule of thumb if you do not have an expensive piece of testing equipment. Your comfort is another good check.

## TYPICAL QUESTIONS ASKED

### 1. Why do moisture requirements vary from home to home?

Requirements depend on the amount and dryness of air to be humidified. The larger and more loosely constructed the home, the greater the quantity of moisture required.

### 2. How can I best check my home's relative humidity?

First give your humidifier time to build up the humidity to an acceptable level. Instruments are available to measure relative humidity, but from a practical standpoint, your comfort is the best guide. You cannot depend on table top or wall hung dial gauges.

### 3. Should my humidifier be connected to softened water?

You should use hard water in your humidifier. A humidifier can, under certain conditions be damaged by soft water. A popular misconception is that a water softener removes minerals. A water softener does not remove minerals but simply changes the mineral state.

### 4. How long will it take my humidifier to build up the humidity in my home?

Much depends on the outside temperature, time of year, home construction, and how dried out the home has become. In some cases, it may take a week or more.

### 5. What are some of the common things that cause higher than average air leakage in the home, therefore causing low humidity?

- A. Jalousie windows
- B. Open fireplace dampers
- C. Cracks around windows and doors
- D. Open doors and windows
- E. Unusually large attic or foundation vents
- F. Range hoods and bath fans

### 6. What else causes static shock besides low humidity?

Some types of carpets tend to create more static than others. While the proper humidity level will reduce the static level, it may not eliminate static entirely.

### 7. What is the safe humidity level for my home?

In order to determine the safe relative humidity for homes exposed to various low outside temperatures, NESCA\* conducted tests and published recommended humidity levels for various outdoor temperatures. These are shown in the chart. These levels help prevent damage to your home such as water running down the walls or even building up inside the walls.

The safe indoor relative humidity percentage is not a fixed number but will increase or decrease as the outdoor temperatures rise or fall.

Outside Temperatures	Maximum Safe Recommended Indoor Relative Humidity
-10° F	20%
0° F	25%
10° F	30%
20° F	35%
30° F	35%

\*NESCA = National Environmental Systems Contractors Association.

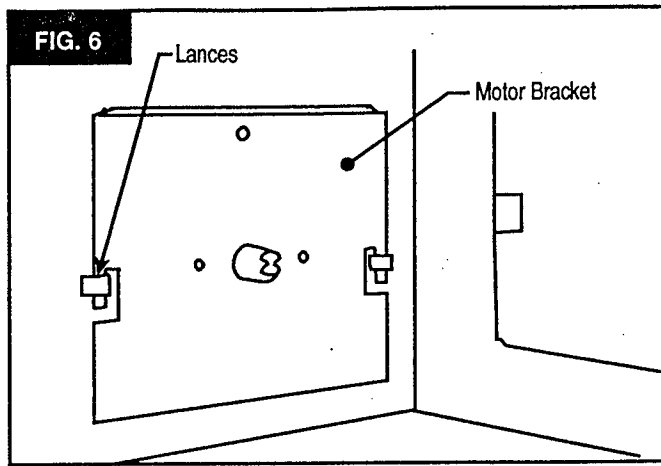

□ **2** Install motor bracket on left side. Make sure bracket is firmly seated (Fig. 6).

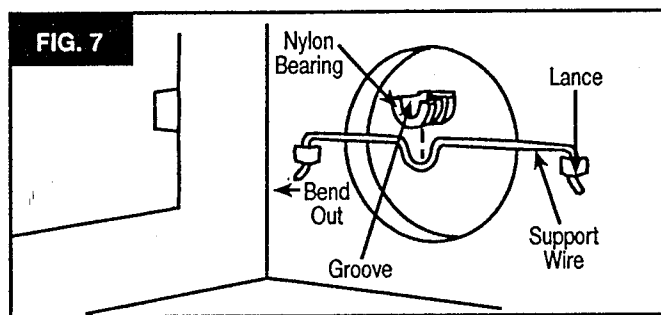

□ **3** Install wire support and nylon bearing in lances on right side. Be sure groove in nylon bearing is toward inside of humidifier. Bend that portion of the wire support leg extending below the lance, outward, to lock support in lances (Fig. 7)

□ **4** After conversion, unit should look like (Fig. 8).

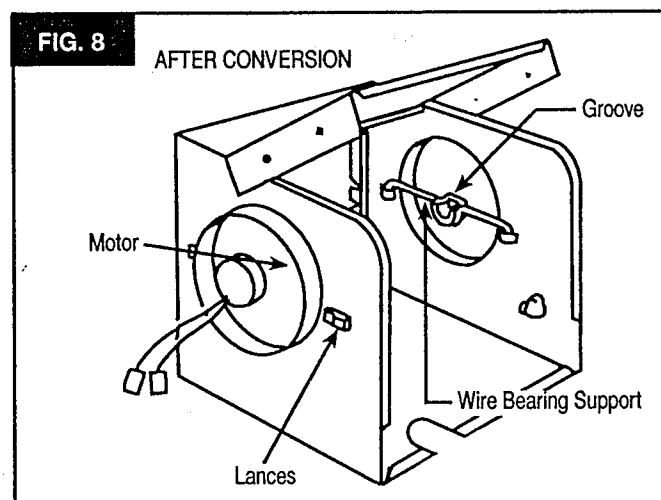

## installation (on sheet metal plenums)

□ **5** Mark a level line on selected plenum at bottom edge location for humidifier.

**NOTE:** Unit must be installed level from left to right and front to back to maintain proper float control of water. See Fig. 10 for clearance required to open cover.

Hold the humidifier housing against the plenum with the bottom edge on the level line. Mark location of the (3) holes and large rectangular opening. Cut opening with tin snips or saw and drill (3) 1/8" diameter holes (Fig. 9).

**CAUTION:** Do not drill into return bends of air conditioning coil.

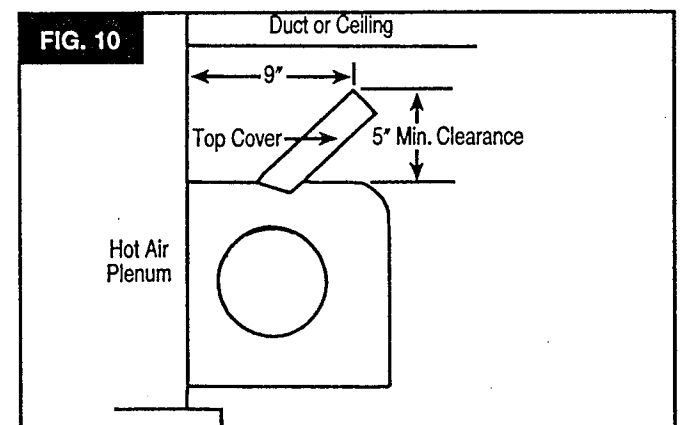
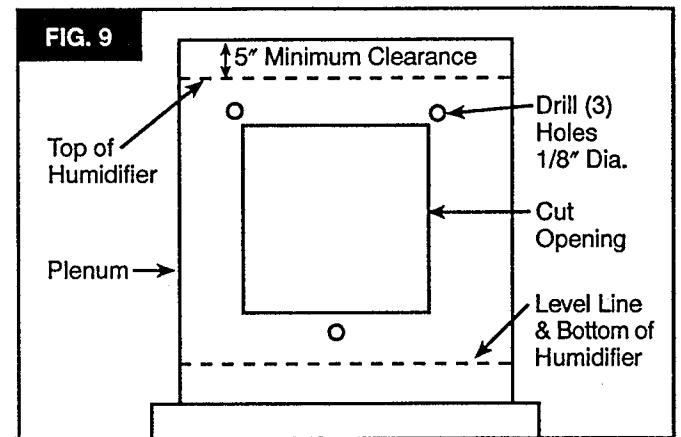

□ **5A** Mount humidifier to hot air plenum using the three screws provided. Bend the two tabs 180° inward to seal humidifier to plenum (Fig. 11).

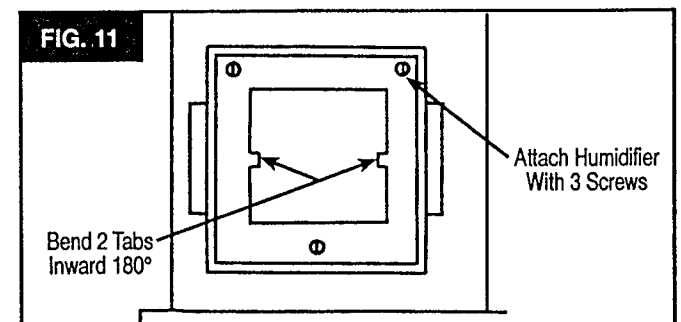

**6** Position collar at selected location on the cold air plenum. Mark center opening and five holes. Cut out center opening and drill five 1/8" holes.

**7** Attach collar and damper to cold air plenum. Use five screws provided. Damper blade fits between cold air plenum and collar (Fig. 12).

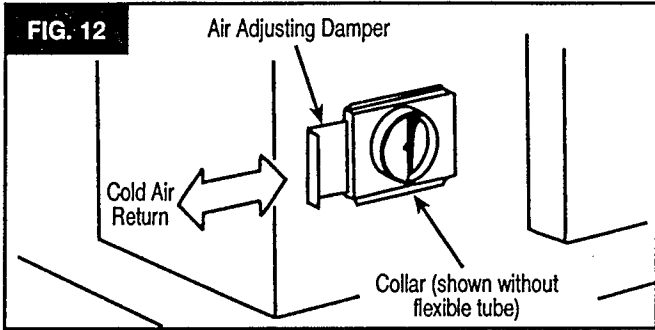

**8** Connect the flexible tube with tube clamps to humidifier and collar. Do not allow flexible tube to come within 3" of furnace flue pipe. If tube is under stress (pulling), it may be necessary to drill two holes in collar for screws. This will prevent the clamp from slipping off (Fig. 13).

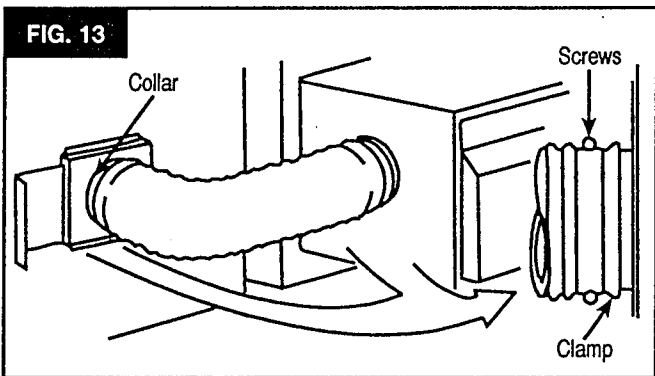

**9** It is best to install an overflow line. Local codes may require overflow protection. The overflow is in the bottom of the reservoir. Use 1/2" inside diameter plastic or rubber tubing to connect drain (tubing not furnished) (Fig. 14).

**NOTE:** Humidifier must be level for drain to work properly.

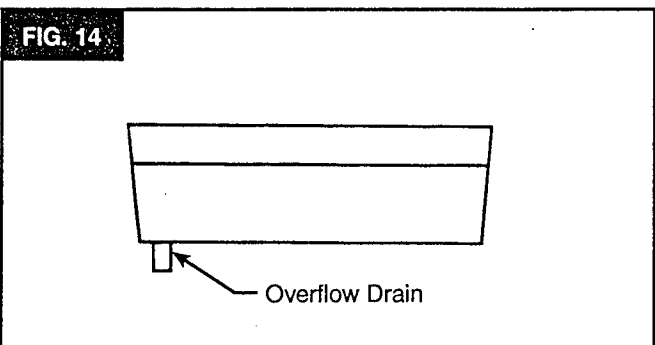

## installation

### WATER SUPPLY

**NOTE:** Tubing must not contact flue pipe or hot air plenum.

**1** Water for the humidifier must be taken from a nearby cold water line. Do not use any line connected to an air conditioner. Turn off the water supply. Drain by opening a faucet at a lower level of the line.

**2** Position the saddle valve on the water line as close to the humidifier as possible. You have been supplied with 10 feet of 1/4" plastic tubing.

**SPECIAL NOTE:** When measuring the distance from the saddle valve location to the humidifier, keep in mind that the tubing must be supported; therefore, it must run along ceiling and walls. Measure along the path the tubing will follow.

**3** Back out the piercing pin by turning the "T" handle counter clockwise and then clamp the saddle valve body securely on the water line with rubber gasket positioned as shown (Fig. 15). On galvanized or copper pipe over 5/8", first drill a 5/32" hole.

**CAUTION:** For safety, use a hand drill or grounded electric drill.

**4** Turn handle clockwise until it has pierced the water line and valve is completely closed (Fig. 15).

**5** Partially uncoil the tubing. Slide the brass compression nut over the tubing. The threads in the nut must face the tubing end. Place brass compression sleeve as shown in Fig. 15. Slip brass insert into end of tubing.

**6** Insert the tubing end into the saddle valve at threaded "A" (Fig. 15) as far as it will go. Thread the brass compression nut onto the valve, then tighten gently with a wrench. Take care not to overtighten the nut.

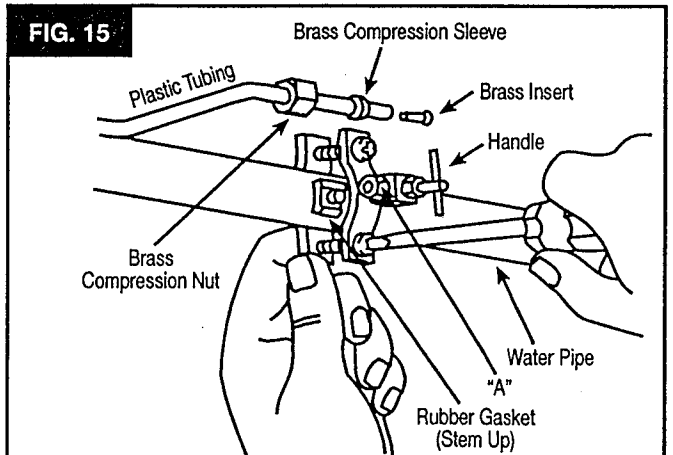

**7** Unwind the rest of the tubing. Take care not to kink it. Run the tubing along flat surfaces to the humidifier. Support the tubing as needed to avoid contact with furnace.

**8** Close previously opened faucet. Turn on main water supply. Place a pail under the end of the tubing. Open the saddle valve. Flush the line. Make sure there are no leaks along the line or at the valve. Turn valve off.

**9** Complete installation of water supply by first sliding plastic compression nut onto the water supply tubing. Insert brass insert into the end of water supply tubing. Insert the tubing into humidifier valve body, making sure it is fully seated. Tighten plastic nut securely, finger tight (no wrench) (Fig. 16).

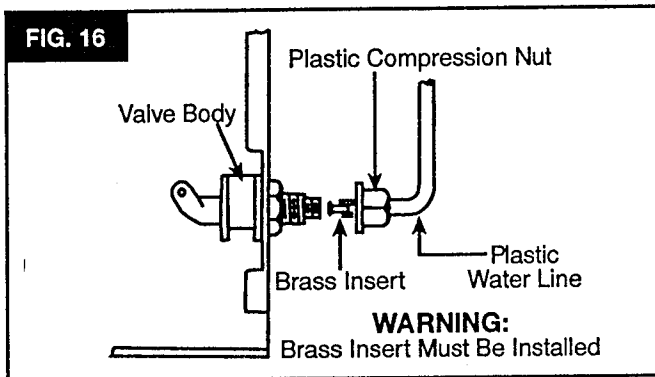

**10** Install reservoir, making sure overflow drain is on left side. Install media wheel. Be sure that media wheel is properly engaged with the media motor and that media wheel shaft is in groove in plastic bearing (Fig. 17).

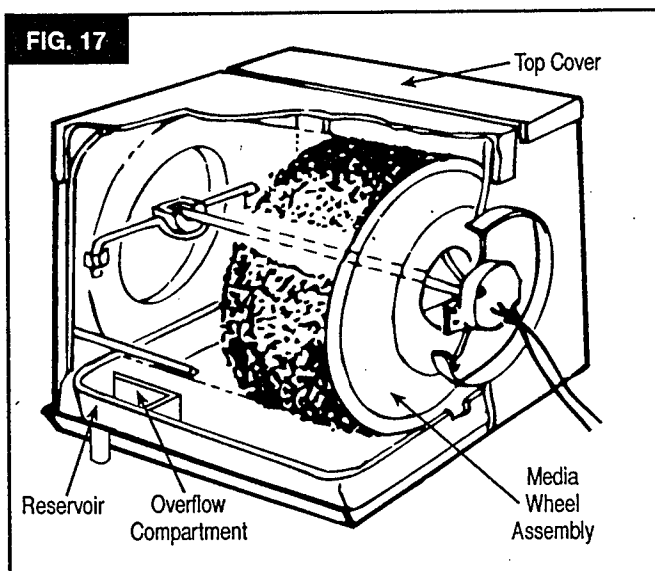

**11** Install float assembly. Place float assembly on valve body; align hole. Slide pivot pin through holes to fasten. Float should have slight up and down movement (Fig. 18).

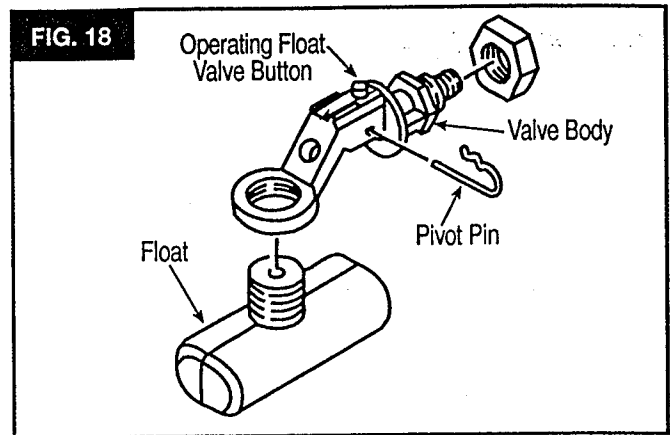

**12** Open saddle valve and allow reservoir to fill. Check water level (Fig. 19). If adjustment is necessary, turn off water and remove float assembly. See instructions on bottom of float. To raise water level, turn float clockwise viewing bottom of float. Water should be 9/16" below the top edge of the reservoir.

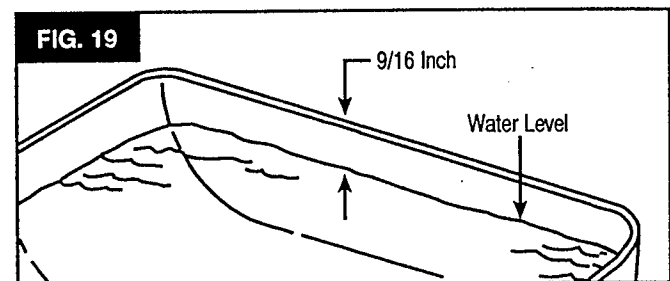

**13** Lower top cover. Install plastic front cover by inserting top edge up under top cover front flange, with side flanges outside casing. Swing bottom of cover in against case and lower down against flange.

## humidistat

The humidistat is designed to mount on the cold air plenum of your furnace or on an interior wall of the home. The cold air plenum, however is the preferred location for sensing the average humidity throughout your home. Select your location and follow the appropriate instructions.

**NOTE: THE HUMIDISTAT AS SUPPLIED IS ASSEMBLED FOR COLD AIR PLENUM INSTALLATION (FIG. 20).**

## cold air plenum mount (Fig. 20)

**1** Select a location that is a minimum of 6" upstream on cold air plenum (Fig. 21). Peel off paper backing and position template supplied, drill (4) 1/8" diameter holes and cut out center portion along solid line. Peel off backing and apply gasket material as indicated by dashed lines.

**CAUTION: DO NOT** install humidistat on hot air plenum.

- 2** Remove knob and cover from humidistat. To remove cover, place screwdriver blade in slot at side of humidistat and twist.
- 3** Position humidistat in opening and fasten with 4 screws provided.
- 4** Install shaft extension. Install cover by snapping onto backplate. Press knob onto shaft extension.
- 5** Connect wiring (Fig. 23). Plug 24 VAC transformer into 120 VAC outlet.
- 6** Peel off backing and attach the operating instruction label onto the cold air plenum next to the humidistat.

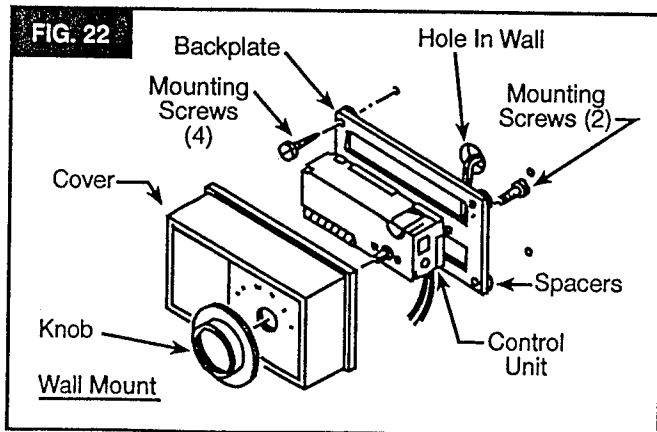
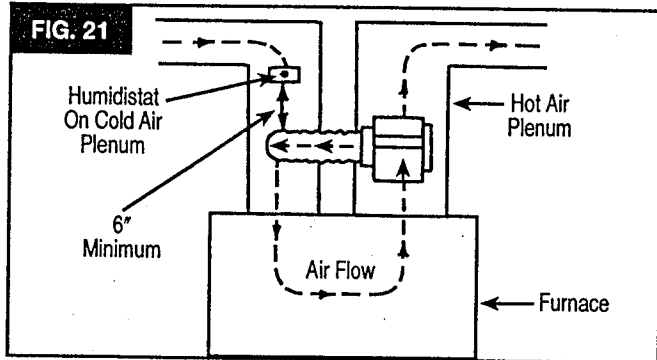
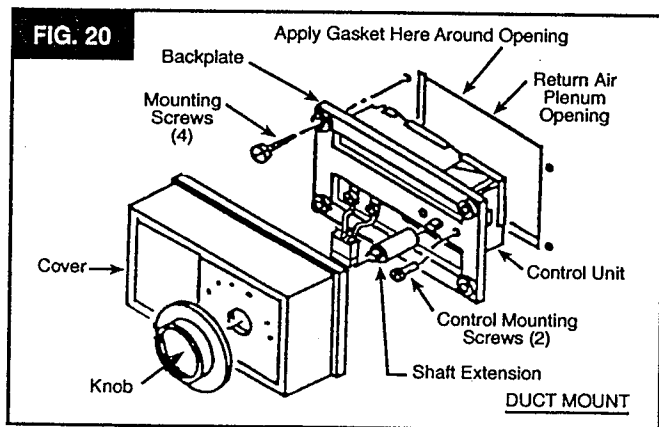

## wall mount (Fig. 22)

- 1** Remove knob and cover from humidistat. To remove cover, place screwdriver blade in slot at side of humidistat and twist.
- 2** Convert humidistat for wall mounting by removing control unit from backplate. Reassemble control unit to backplate as illustrated in (Fig. 22) with spacers to rear and shaft forward. Remove electrical disconnect by cutting the (2) wires. Strip ends 1/2" for splicing to wall wire.

**NOTE:** Shaft extension is not required for wall mounting.

- 3** Select a location on a convenient inside wall, usually beside your furnace thermostat.
- 4** Run low voltage wire through the wall. Exit hole must be within the lower backplate opening. (Purchase additional wire as required.)
- 5** Connect low voltage wires from wall to previously cut leads on humidistat by stripping ends and using wire nuts (not provided). Position and fasten humidistat to wall with 4 screws provided. Install cover by snapping onto backplate. Press knob onto humidistat shaft. Make sure 1/8" air space is maintained between wall and backplate to allow air circulation and humidity sensing.
- 6** Connect wiring (Fig. 23). Remove electrical disconnect by cutting wires on harness, strip ends and splice to low voltage wire from wall humidistat using wire nuts. (Wire nuts not provided.) Plug 24 VAC transformer into 120 VAC outlet. Do not use existing transformer on furnace.

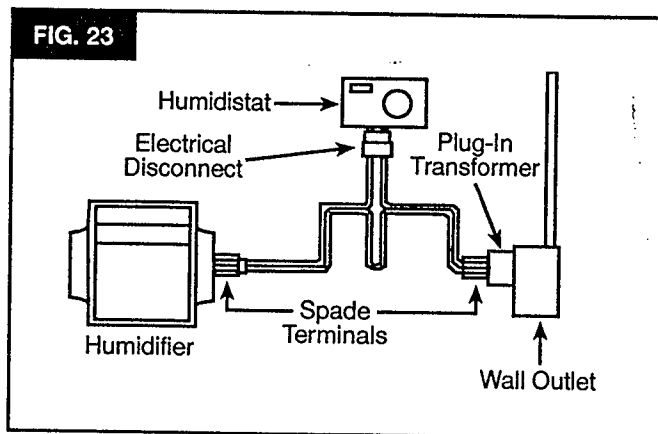

## operation

- 1** Set knob to the lowest temperature predicted for a 24-hour period. Because of differences in house construction you may want to try a higher or lower setting to achieve proper humidity.

**NOTE:** Humidifier humidifies only when furnace is on, however, Media Wheel will turn whenever humidistat calls for humidity.

- 2** Change knob settings as outdoor temperature changes occur.

**WARNING:**  
**DO NOT LEAVE KNOB SET ABOVE "+20" OR HUMIDIFIER WILL RUN CONSTANTLY AND MAY OVER HUMIDIFY YOUR HOME.**

### IF SWEATING OF WINDOWS OR WALLS OCCURS OR IF AIR IS TOO DRY:

Check dial setting. Indicator should point to the lowest 24 hour temperature. If setting does not agree, readjust knob to proper number and wait 24 hours for sweating to stop. If dial setting was correct and conditions have not changed, rotate knob back and forth from TEST to MINIMUM HUMIDITY SETTING. If humidifier goes ON and OFF, control is operating properly.

### SPLASH INSIDE HUMIDIFIER:

This humidifier depends on the difference of air pressure between the supply air plenum and the return air plenum to propel air through the humidifier. Some furnaces have higher pressures than others. This could result in air traveling at high speed through the humidifier. This can cause droplets of water to be picked up and splashed against the inside of the humidifier case. Eventually a coating of lime will build up. It could in extreme cases, cause leaking of water from the humidifier. If possible, operate the furnace blower at a lower speed.

### TO REDUCE SPLASH:

Partially close the damper located in the collar on the return air plenum. Some experimenting may be necessary to find the proper setting.

### AIR CONDITIONING – IMPORTANT:

If your furnace has air conditioning (cooling), close the damper completely during summer months and turn the humidistat to the Minimum Humidity setting. BE SURE TO OPEN DAMPER DURING HEATING SEASON.

### CAUTION:

**Do not use tablets in an attempt to control lime deposits in this humidifier! Use of tablets may cause humidifier to splash causing damage to humidifier or furnace.**

## maintenance

### CLEANING AND SERVICE INSTRUCTIONS:

The humidifier is an appliance that works with water. The dissolved minerals normally found in tap water are left as lime deposits in the humidifier. **REGULAR CLEANING** is necessary to keep the parts free of lime deposits. Deposit buildup will reduce humidifier output. Ease of servicing has been foremost in the design of this humidifier. **Service at least every (4) four weeks during the heating season or more often depending on the water conditions.**

1. Unplug transformer.
2. Close saddle valve.
3. Remove the front plastic panel and lift up top hinged cover.
4. Pull out pivot pin and remove float and float arm.
5. Lift out the media wheel and reservoir.
6. Pour contents of reservoir down the drain.
7. Clean lime from all parts using a solution of vinegar and water, detergent and water.
8. Remove media pad from inside of wheel and clean thoroughly, replace if necessary. **IMPORTANT: Stretch new media lengthwise before placing in wheel.**
9. If the Reservoir has been overflowing, the operating Float Valve Button may be worn. Remove the operating Float Valve Button, turn it over and reinsert or replace after both surfaces are worn (Fig. 24).
10. Reinstall reservoir, media wheel with pad, float and pivot pin.
11. Open saddle valve and check water level in reservoir. Adjust float as required.
12. Close top metal hinged cover and replace front plastic cover.
13. Plug in transformer.
14. Turn humidistat to "test" momentarily and check for media wheel rotation. Reset humidistat according to outdoor temperature as instructed on label and reinstall front cover. Unit is back in operation.

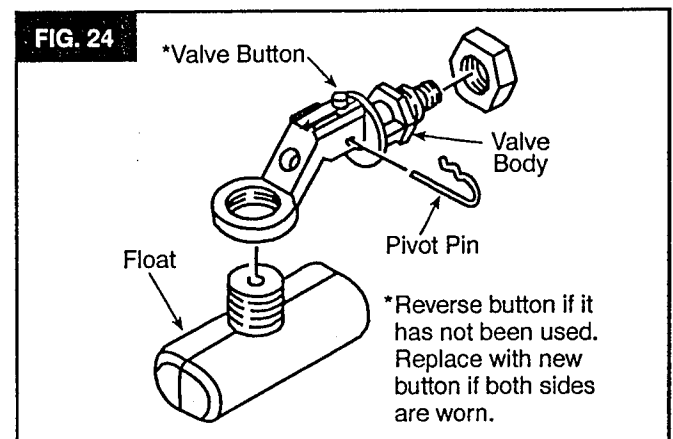

## SUMMER SHUT DOWN:

Unplug transformer, close saddle valve, close bypass damper. (CLEAN PER ABOVE AND LEAVE RESERVOIR EMPTY.) As a reminder, you may want to put a tag or sticker on the unit indicating it has been shut down for the summer and will require start up in the fall.

## FALL START UP:

Plug in transformer, open saddle valve, open bypass damper and set humidistat to TEST position. Check for proper water level and media wheel operation. Set humidistat according to outdoor temperature as instructed on label.

## SERVICING THE FLOAT

If the humidifier has been overflowing, the float valve button may be worn. This button will wear much like a faucet washer. To service:

1. Turn off water at saddle valve.
2. Remove float from humidifier (pull out pivot pin).
3. Service float as shown in Fig. 24.
4. Reinstall, turn on water at saddle valve and test float.

## service hints

Frequently what seems to be a major problem can be solved very easily. Listed below are the common concerns with any humidifier.

Check the simple things first. Remove the front panel and see if there is a crusty, white lime buildup on the media pad. The lime buildup won't hurt the humidifier, but will reduce its output. Low output might just mean your humidifier needs cleaning. While you're checking for lime buildup, look to see if the media wheel is turning. If not, check the power supply.

CONDITION	WHAT TO CHECK	WHAT TO DO
Too little Humidity	<ol style="list-style-type: none"> <li>1. Does humidifier need cleaning.</li> <li>2. Is media wheel rotating?</li> <li>3. Humidistat setting.</li> <li>4. Water to unit.</li> <li>5. Excessive air loss in house.</li> <li>6. Is water level correct?</li> <li>7. Is damper open?</li> </ol>	<ol style="list-style-type: none"> <li>1. Clean humidifier and clean or replace media pad.</li> <li>2.               <ol style="list-style-type: none"> <li>a. Clean or replace media pad.</li> <li>b. Check to see if transformer is properly plugged in.</li> <li>c. Inspect main fuse or circuit breaker.</li> <li>d. Check to see if media motor is rotating.</li> <li>e. Humidistat setting too low, turn knob clockwise to increase humidity.</li> </ol> </li> <li>3. Set for proper outdoor temperature - lowest 24 hour temperature.</li> <li>4. Turn on saddle valve and check for possible obstruction in water line. Is water supply connected?</li> <li>5. Close fireplace damper, seal around doors and windows.</li> <li>6. Adjust float.</li> <li>7. Slide damper out for winter operation.</li> </ol>
Too much Humidity	<ol style="list-style-type: none"> <li>1. Humidistat setting.</li> <li>2. Other humidification sources.</li> </ol>	<ol style="list-style-type: none"> <li>1. Turn knob counterclockwise to decrease humidity.</li> <li>2. May be a temporary condition caused by moisture from laundering, bathing, cooking, etc.</li> </ol>
Humidifier Overflows	<ol style="list-style-type: none"> <li>1. Is humidifier level?</li> <li>2. Float valve.</li> <li>3. Air flow too high.</li> </ol>	<ol style="list-style-type: none"> <li>1. Level unit.</li> <li>2. Service as shown in Fig. 24.</li> <li>3. Adjust damper.</li> </ol>
Humidifier Making Noise	<ol style="list-style-type: none"> <li>1. Mounting or plenum.</li> <li>2. Water pressure.</li> <li>3. Media Wheel.</li> </ol>	<ol style="list-style-type: none"> <li>1. Tighten all fasteners.</li> <li>2. A slight sound is normal as water enters humidifier.</li> <li>3. Check clearance of media wheel in reservoir.</li> </ol>
Humidifier Motor Comes On When Furnace Isn't Running	<p>This is a normal condition</p> <ol style="list-style-type: none"> <li>1. If heating season is over.</li> <li>2. If heating season is just starting.</li> </ol>	<ol style="list-style-type: none"> <li>1. Turn knob on humidistat to minimum setting.</li> <li>2. This is a normal condition since humidistat is controlling humidifier.</li> </ol>

# repair parts

MODEL NO. FM90

WHEN ORDERING REPAIR PARTS, ALWAYS GIVE THE FOLLOWING INFORMATION:

1. The Part Number in this list.
2. The Part Description in this list.
3. The Model Number of your humidifier which is FM90.

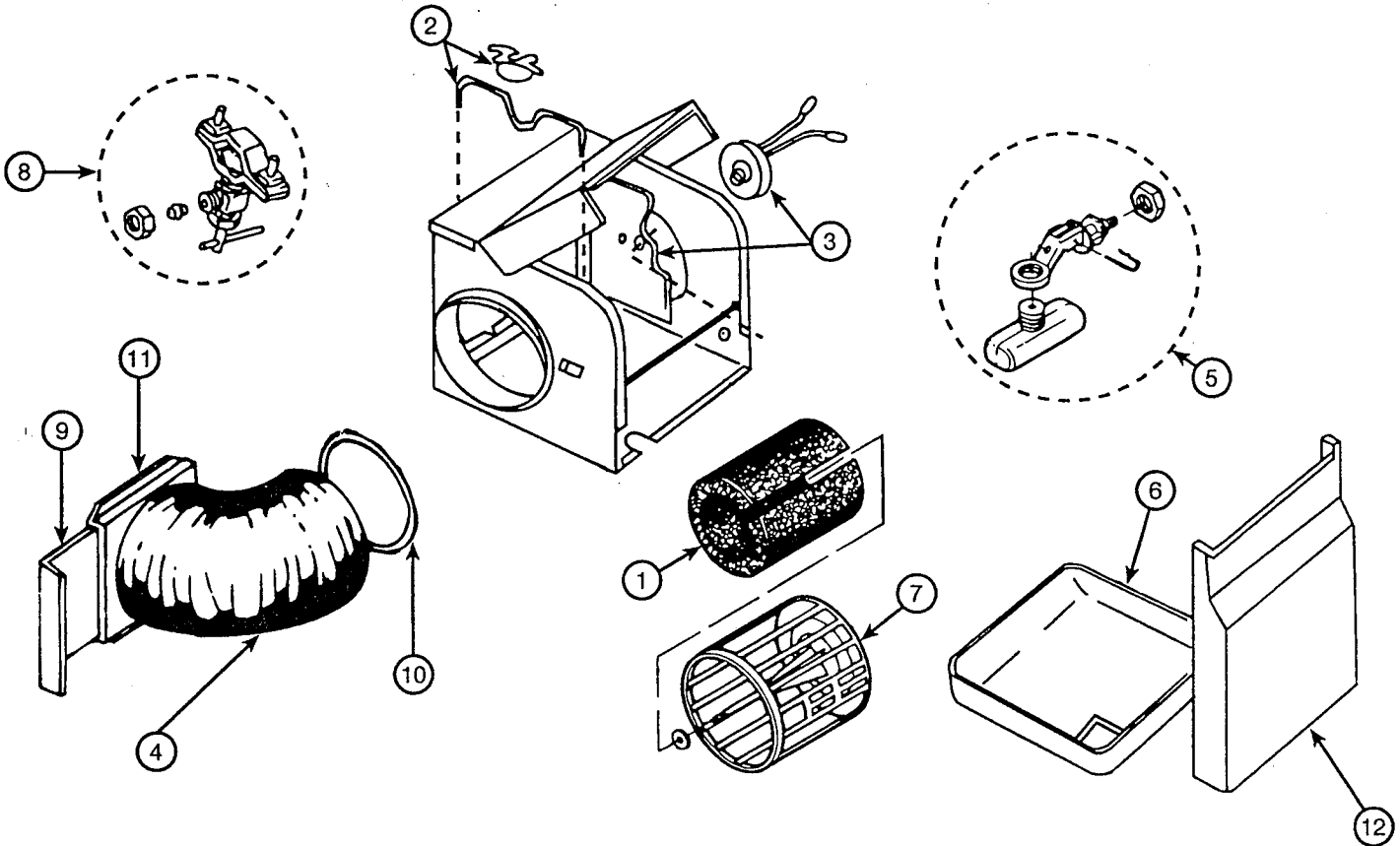

KEY NO.	PART NO.	DESCRIPTION
1	411069-05	Media Pad
2	404370-01	Bearing and Wire Assembly
3	404713-01	Motor 24 Volt
4	420694-03	Flexible Duct
5	355761-02	Float Assembly
6	431289-02	Reservoir
7	440065-01	Media Wheel Assembly
8	355618-01	Saddle Valve Assembly
9	431489-01	Damper
10	215994-02	Duct Clamp
11	431490-01	Collar
12	431610-08	Front Cover
*	355873-03	Humidistat 24 Volt
*	355759-01	Transformer 24 Volt

THIS IS A PARTS LIST, NOT A PACKING LIST.

\*Not Shown



# FreshMist90

## FM 90 CENTRAL SYSTEM HUMIDIFIER

Now that you have purchased your humidifier, should a need ever exist for repair parts or service, simply contact the retailer where purchased. Be sure to provide all pertinent facts when you call or visit.

THE MODEL NUMBER OF YOUR HUMIDIFIER IS: FM90

WHEN ORDERING REPAIR PARTS, ALWAYS GIVE THE FOLLOWING INFORMATION:

1. Part Number
2. Part Description
3. Model Number

FOR FUTURE REFERENCE FILL OUT THE FOLLOWING INFORMATION AT TIME OF PURCHASE:

PURCHASED DATE: \_\_\_\_\_

WHERE PURCHASED: \_\_\_\_\_

\_\_\_\_\_



THE FIELD CONTROLS CO.

2308 AIRPORT RD.  
KINSTON, NC 28501-8928  
PHONE: (919) 522-3031  
FAX: (919) 522-0214

(A DIVISION OF HEICO, INC. • LISLE, IL)