

PRESSURE-SENSING MAKEUP AIR SENSOR

Model: P-Sensor



The P-Sensor Electronic Makeup Air Sensor is intended for use as an accessory to the HHSC+ Ventilation Control and FAD fresh air damper system, and/or optional E-Sensor Enthalpy Damper Control or T-Sensor Temperature Damper Control (items not included). The P-Sensor senses a change air in pressure within the exhaust duct of an exhausting device such as a kitchen range hood, clothes dryer, central exhaust system etc., and sends a signal to a makeup air system, such as the HHSC+ ventilation system, in order to provide makeup air for the exhausting device. The P-Sensor may also be used in a stand-alone passive makeup air system to control a 24V fresh air damper that is ducted to the outdoors.

ITEMS INCLUDED IN KIT:

- 1-Adjustable Pressure Switch (differential type, may install upstream or downstream of fan)
- 1-Sensing Probe Kit (sensing tube, 3' of clear vinyl air tubing)
- Wiring connectors (female 1/4"x.031" quick connect)
- Mounting screws/fasteners for pressure switch and probe

INSTALLER-SUPPLIED ITEMS:

- 24V Wiring (max 50' with min 22AWG, or max 150' with min 18AWG)

READ THESE INSTRUCTIONS CAREFULLY AND COMPLETELY BEFORE PROCEEDING WITH THE INSTALLATION.

This device **MUST** be installed by a qualified agency in accordance with the manufacturer's installation instructions. The definition of a qualified agency is: any individual, firm, corporation or company which either in person or through a representative is engaged in, and is responsible for, the installation and operation of HVAC appliances, who is experienced in such work, familiar with all the precautions required, and has complied with all the requirements of the authority having jurisdiction.

Please retain these instructions after installation.

Installed By: _____ Phone: _____ Installation Date: _____



FIELD CONTROLS
www.fieldcontrols.com

INSTALLATION

1. Install the HHSC+ Ventilation Control, FAD Fresh Air Damper, E-Sensor Enthalpy Control or T-Sensor Temperature Control (if used), and wiring required to connect to the Pressure Switch: Follow the instructions for installation included with the HHSC+ and refer to the Wiring Diagrams in these instructions to determine the desired wiring configuration.

Figure 1

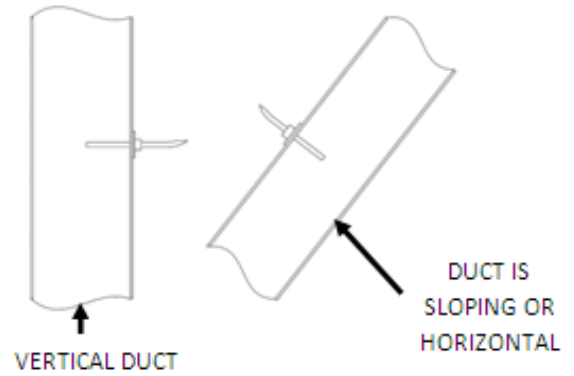

2. Install the Sensing Probe Kit on the exhaust duct:
 - a. Choose a location for the sensing tube as far from fans and bends or elbows as possible, in a location within 32" of a suitable mounting place for the Pressure Switch (see Step 3).
 - b. Drill a 1/4" hole in the exhaust duct. To avoid accumulation of moisture in the sensing tube, drill the hole on the top side of the duct if the duct is not vertical (see Figure 1). DO NOT drill the hole on the underside of a duct that is not vertical.
 - c. Install the small set screw into the hub of the mounting flange (see Figure 2).
 - d. Insert the straight end of the sensing tube (see Figure 2) through the mounting flange as shown.
 - e. Insert the sensing tube into the duct, orient the mounting flange such that the arrow on the flange points in the direction of air flow going to the outdoor vent hood, and install the two self-threading mounting screws through the mounting flange into the duct (see Figures 1 and 2). It may be necessary to drill 3/32" pilot holes for the screws, depending on the type of duct.
 - f. Make sure that the sensing tube penetrates into the duct by at least 1", turn the tube so that the curved end points upward (Figure 1), and tighten the set screw on the mounting flange hub.

Figure 2

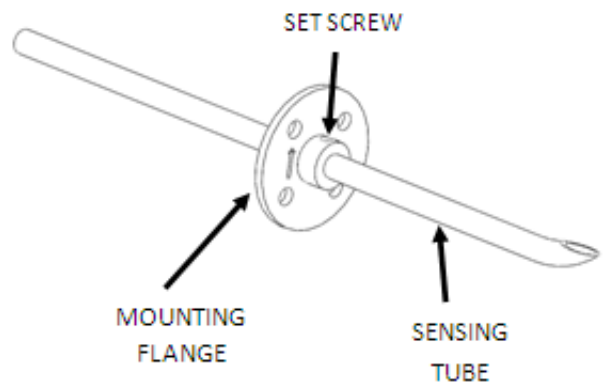

Figure 3

3. Mount the Adjustable Pressure Switch to a solid surface in a dry and protected location, within range of the sensing tube. Mount the switch elevated higher than the sensing tube as much as possible, with the pressure ports pointing downward, so that moisture will not tend to accumulate in the tubing or the switch (see Figure 3). NOTE: the pressure switch MUST be mounted with the switch diaphragm in a vertical plane; see Figure 3. The switch is properly mounted if a spirit level may be held to the larger sides of the switch with the plumb (vertical) bubble between the lines.
4. For systems with the fan(s) located within the exhausting device, or remote fan UPSTREAM of the sensing tube (tube between the fan and the outdoor exhaust termination): Using the flexible vinyl tubing included with the kit, connect the sensing probe air tube to the HIGHT port of the pressure switch (see figure 3). The switch will be operated by positive pressure (not vacuum) in the exhaust duct. Trim and route the air tube such that any moisture accumulated in the tube will tend to drain back through the sensing tube.

5. For systems with a remote fan DOWNSTREAM of the sensing tube (tube between the exhausting device and the fan): Using the flexible vinyl tubing included with the kit, connect the sensing probe air tube to the LOW port of the pressure switch (see Figure 3). The switch will be operated by negative pressure (vacuum) in the exhaust duct. Trim and route the air tube such that any moisture accumulated in the tube will tend to drain back through the sensing tube.
6. The pressure switch port not being used may be left open, or a short piece of air tubing may be connected and either left open or connected to a small air filter if exposure to insects or significant contamination is anticipated; a small bit of insulation material or a clean cigarette filter may be inserted in the end of the tube, for example.
7. Install the wiring to HHSC+ Ventilation Control (Diagram A), or if installed as a passive stand-alone system, to the FAD damper and 24 VAC transformer (not included), see Diagram B. If an optional E-Sensor or T-Sensor damper control is also installed, refer to instructions included with those models for details pertaining to system configuration selection, wiring, and specific operation of the system..
8. Adjust the Air Pressure Switch:
 - a. Turn on the exhausting device to the highest exhaust rate, or lowest setting that is greater than (or equal to) 400 cfm, according to the manufacturer's air flow ratings, as applicable.
 - b. Turn the adjustment screw on the pressure switch clockwise, to a higher set point, until the switch deactivates, if it is not already de-activated. The switch will be de-activated when there is no electrical continuity from the COM terminal to the N.O. terminal.
 - c. Turn the adjustment screw counter-clockwise, to a lower set point, until the pressure switch activates.
 - d. Turn the adjustment screw $\frac{1}{4}$ to $\frac{1}{2}$ of a turn more, counterclockwise. The switch should still be activated.
9. Restore Power to the HHSC+: When the exhausting device is operated on a setting at or above 400, CFM, the FAD damper should open, and remain open, and depending on system configuration, the HVAC system fan should operate, until the range hood fan is shut off.

TROUBLESHOOTING

1. If the damper does not open, check the modular plug connection to the damper, and for voltage from terminal R to C on the HHSC+.
2. If the damper does not close, check the mode switch on the damper motor (see Step 1), and for voltage from red to white.
3. If the damper opens and immediately closes, or continues to rotate, turn the pressure switch adjusting screw another $\frac{1}{2}$ turn counterclockwise at a time until the damper remains open.

WIRING DIAGRAM A

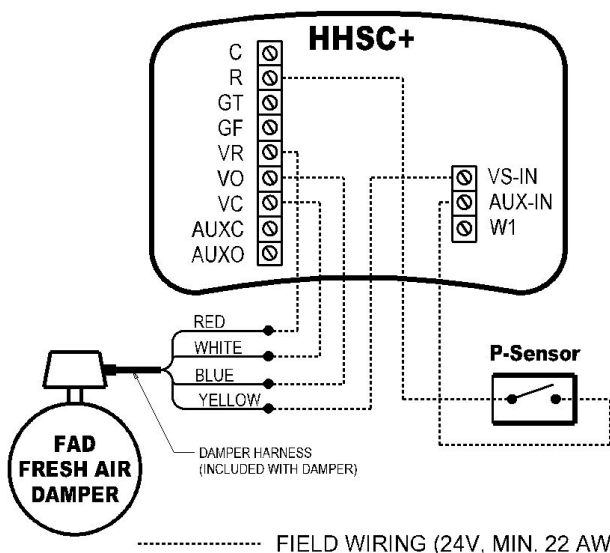

* HVAC AND OTHER WIRING NOT SHOWN
 ** MAY BE MODEL P-SENSOR OR MODEL C-SENSOR

WIRING DIAGRAM B

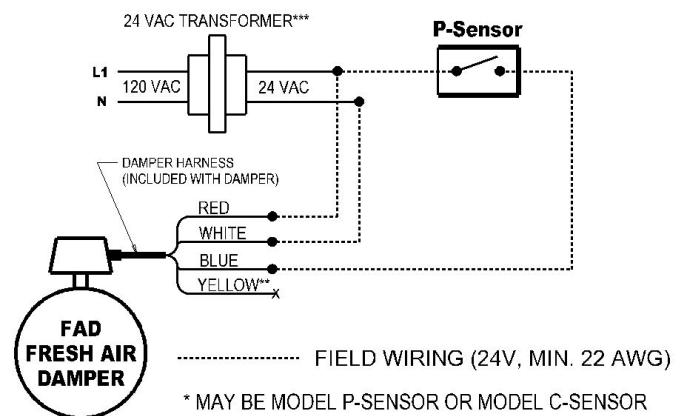

* MAY BE MODEL P-SENSOR OR MODEL C-SENSOR
 ** NOT USED, CAP OFF IF PRESENT
 *** NOT INCLUDED, MIN. 10VA

Warranty

For warranty information about this or any Field Controls product, visit:
www.fieldcontrols.com/warranty



FIELD CONTROLS

Phone: 252.522.3031 • Fax: 252.522.0214
www.fieldcontrols.com