

# COMBUSTION AIR SYSTEM

MODEL: CAS-4

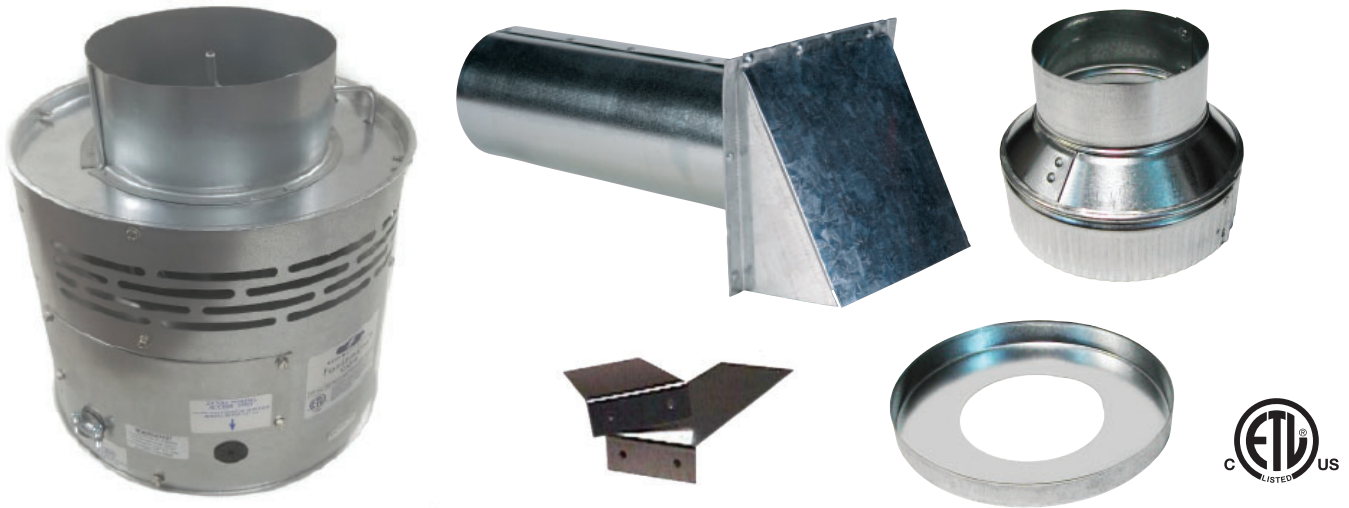

This product is designed for use with any natural gas or LP burning furnace, water heater, or boiler with a 24 VAC control system. The CAS-4 may be used with one 24V-controlled combustion heating appliance and one 30mV standing-pilot gas water heater with the use of an additional CK-20 series control kit. Additional 120V or 24V-controlled appliances may also be served by the CAS-4 with the addition of one CAC-120 or CAC-24 control kit per each additional appliance (see note)\*. The CAS unit mechanically draws air into a structure and disperses it near the combustion air intake of an appliance. Refer to Diagrams A and B for guidance in setting up the CAS system based on the size and length of the connecting ductwork and the input rating of the appliance.

#### ITEMS INCLUDED IN KIT:

- |  |                                       |
|--|---------------------------------------|
| 1- Motorized Blower                              | 1- 4" galvanized intake air Vent Hood |
| 2- Mounting brackets to secure the CAS to a wall | 2- Wire/conduit connectors            |
| 1- 4" x 6" Pipe Increaser Fitting                | 1- 6" Orifice Ring                    |
| 1- Instruction Sheet                             | 1- High/Low Motor Speed Switch        |



**WARNING! CONNECTIONS TO MULTIPLE APPLIANCES MUST FOLLOW INSTALLATION INSTRUCTION WIRING DIAGRAMS. FOR HELP CALL 1-800-742-8368.**

\*NOTE: The model CAS-4 design has recently been changed. Please note that there are differences in construction, operation, and installation of this CAS as compared to legacy product. Also, note that for multiple-appliance installations, each additional appliance will require either a CAC-24 or CAC-120 control kit be provided for that appliance. Installations with one heating appliance and one 30mV gas water heater will require an additional CK-20 series control kit in addition to the CAS-4.

#### READ THESE INSTRUCTIONS CAREFULLY AND COMPLETELY BEFORE PROCEEDING WITH THE INSTALLATION.

This device **MUST** be installed by a qualified agency in accordance with the manufacturer's installation instructions. The definition of a qualified agency is: any individual, firm, corporation or company which either in person or through a representative is engaged in, and is responsible for, the installation and operation of HVAC appliances, who is experienced in such work, familiar with all the precautions required, and has complied with all the requirements of the authority having jurisdiction.

Please retain these instructions after installation.

Installed By: \_\_\_\_\_ Phone: \_\_\_\_\_ Installation Date: \_\_\_\_\_



**FIELD CONTROLS**

www.fieldcontrols.com

P/N 46284600 Rev L 09/19

## GENERAL SYSTEM OPERATION

1. The thermostat (wall thermostat, or aquastat) calls for heat and energizes a relay which activates the CAS unit. After the CAS fan has come up to speed and air flow into the CAS inlet is established, an internal air pressure switch closes and completes the circuit to allow the burner to fire. If the appliance is power vented, the venter and CAS activate simultaneously. After the CAS and power venter have come up to speed, a pressure switch in the power venter control also closes and allows the appliance to fire.
2. After the heating requirement has been satisfied, the thermostat circuit will open and deactivate the burner and CAS unit.
3. For power vented systems with a post purge device, the power venter and CAS operate for a period of time after the burner has shut off to purge remaining flue gases from the vent system.

## INSTALLATION SAFETY INSTRUCTIONS

**CAUTION:** This device must be installed by a qualified installer in accordance with the manufacturer's installation instructions.

1. This combustion air system must be installed by a qualified installer. "Qualified Installer" shall mean an individual who has been properly trained or a licensed installer.
2. Plan the system layout before installation to avoid the possibility of accidental contact with concealed wiring or plumbing inside walls.
3. Disconnect power supply before making wiring connections to prevent electrical shock and equipment damage.

## SIZING AND SETUP

Diagrams A and B and Table 1 show the maximum equivalent length and size of duct pipe that should be used when installing the CAS system. Using these charts will help ensure that the proper amount of air is drawn into the structure as needed by the appliance. The defined regions shown correspond to the CAS's airflow characteristics when using 4" and 6" diameter sheet metal duct pipe and the included orifice ring. Follow the guidelines below to properly size and setup the CAS.

1. Determine the maximum input firing rate of the appliance, or the maximum total firing rate of multiple appliances that will be used.
2. Position the motorized CAS unit according to the guidelines in the Installation section.
3. Determine where the intake air vent hood will be located based on the recommendations in the Installation section.
4. The CAS is equipped with a High/Low motor speed control switch. When calculating the maximum equivalent feet, determine which speed is appropriate for the application. (Refer to Diagram A or B or Table 1)
5. Calculate the total equivalent length of duct pipe including elbows and fittings needed to connect the CAS unit to the vent hood. (Refer to Diagram A or B or Table 1)
6. On Diagram A or B, locate the point that corresponds to the firing rate along the horizontal axis and the equivalent length of the duct pipe along the vertical axis, if using for make up air.
7. The point should fall within one of the three regions on the table. Each region corresponds to a duct pipe diameter of 4", 4" using the orifice ring, and 6" respectively.

EXAMPLE: A gas fired appliance firing at 100,000 BTU/hr. where the CAS unit needs to be placed 30 equivalent feet from the intake hood.

From Diagram A or B, the point at 100,000 BTU/hr. on the Gas Firing Rate scale and 30 equivalent feet falls in the 4" Duct, Hood, and Orifice Ring region. The point is approximately 2/3 of the horizontal distance between the left and right boundary of the region. The left boundary is the edge of the graph, the right boundary is the diagonal line that says 4" Duct, Hood & Orifice Ring. Therefore, place the Orifice Ring into the inlet of the CAS so that it sits on the ledge above the fan. It does not matter which way the Orifice Ring is turned as long as it is pushed down against the ledge completely. Use 4" diameter pipe to connect the vent hood and the CAS unit.

Table 1

TOTAL INPUT OF APPLIANCE  CAS-4, 4mV Gas (BTU/hr.)	MAXIMUM EQUIVALENT FEET OF INSTALLATION					
	4" Duct And Hood w/ Restrictor		4" Duct and 4" Intake Air Hood		6" Duct and 6" Intake Air Hood	
	HI	LOW	HI	LOW	HI	LOW
50,000	300	300	300	300	300	300
75,000	300	300	300	300	300	300
100,000	300	300	300	300	300	300
125,000	300	220	300	220	300	300
150,000	174	108	232	118	300	300
175,000	99	48	152	63	300	300
200,000	52	14	102	32	300	300
225,000	20	NA	68	13	300	239
250,000	NA	NA	45	NA	300	150
300,000	NA	NA	16	NA	300	53
350,000	NA	NA	NA	NA	193	8
400,000	NA	NA	NA	NA	109	NA
450,000	NA	NA	NA	NA	56	NA

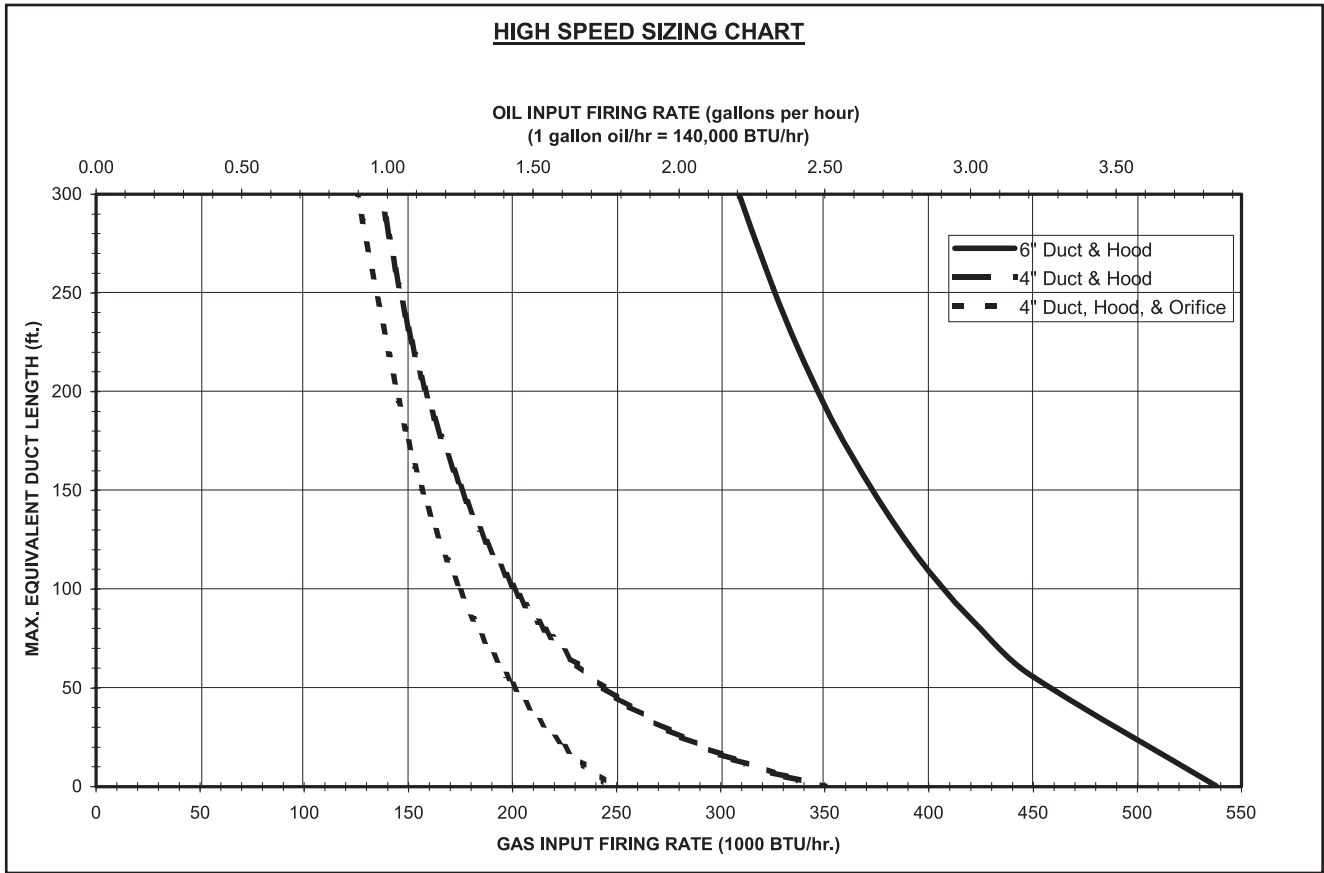

Diagram A

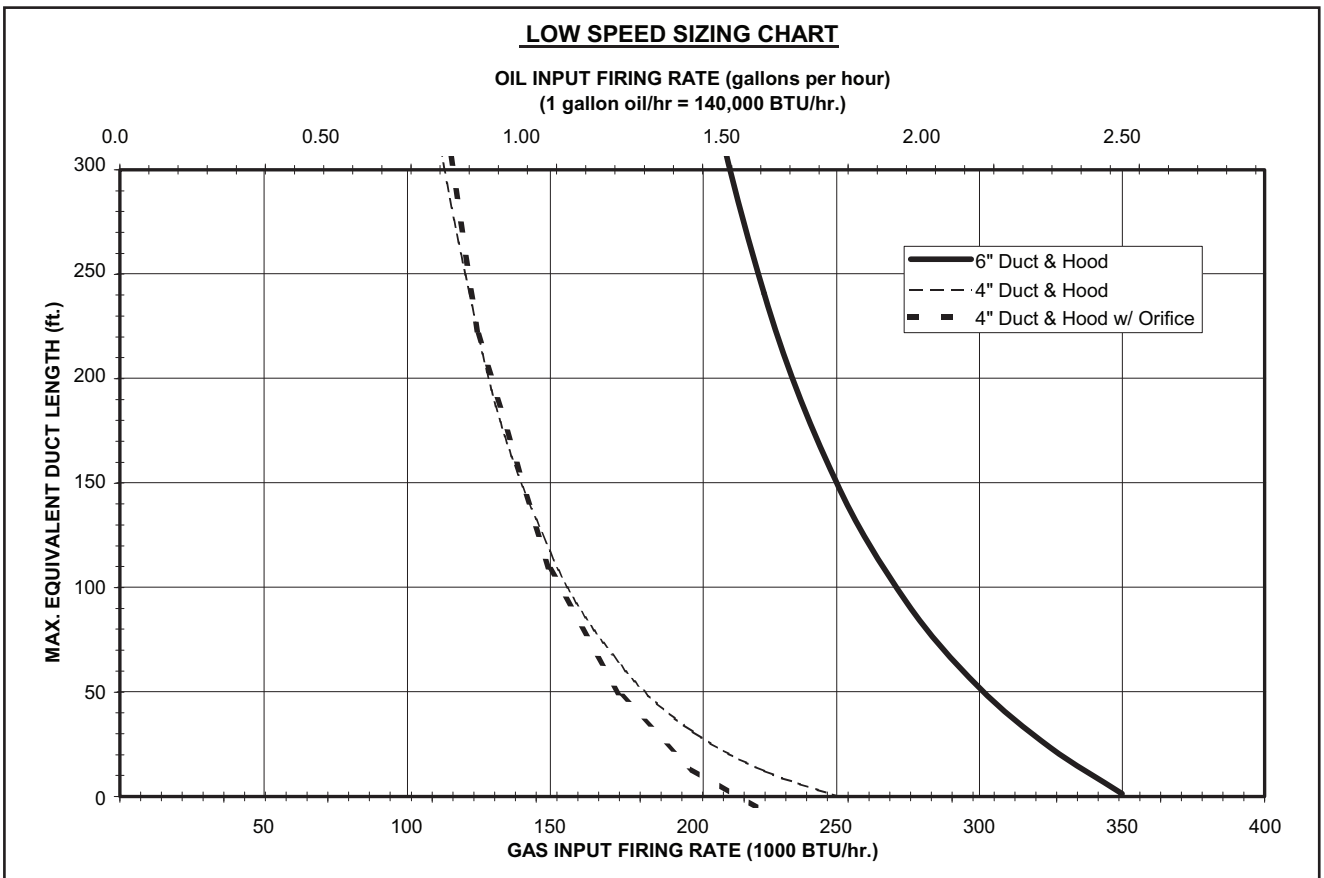

Diagram B

## INSTALLATION

### PLACEMENT OF THE CAS UNIT

The motorized CAS unit should be located on a flat horizontal surface within the same space as the appliance and within 3' of the combustion air intake as possible. Two mounting brackets are provided for securing the unit against a solid structure, such as a wall, column, or the side of the appliance itself. Use the included screws to attach the brackets to the CAS housing as shown in Figure 1. Secure the brackets to a solid structure with appropriate fasteners. It is not required to use the brackets as long as the unit is located so that it may not be bumped, moved, or tipped over.

### INTAKE AIR HOOD LOCATION

The 4" galvanized vent hood should be located on an outside wall maintaining minimum clearances to other intake and exhaust vents in accordance with the National Fuel Gas Code, ANSI Z223.1, manufacturer's recommendations and/or local codes which are applicable. The hood should be located at least 10' from a power vented exhaust outlet and should be on the same wall. The intake air hood should be a minimum of 1' above grade or snowlines where applicable.

### INSTALLATION OF INTAKE AIR HOOD

After determining the location of the vent hood, cut a 4 1/2" round or square hole in the wall. Insert the vent hood and secure with appropriate fasteners. Take precautions to avoid interference with wiring or other plumbing in the wall to be cut.

### INSTALLATION OF DUCT

Refer to Diagram A or B to determine what size pipe is needed. Connect the duct pipe from the top of the CAS unit to the Vent Hood in the wall. If using 4" diameter pipe attach the provided 4" x 6" Pipe Increaser Fitting to the top of the CAS unit. The duct should be supported with appropriate mounting straps from floor joists, walls, or other solid structures. The straps should be placed so as to keep the ductwork out of passageways. (See Figure 2) A minimum of 12' of pipe should be run to help temper outside air being drawn in. All joints in the duct system must be sealed by appropriate tape or other means meeting all applicable building and mechanical codes.

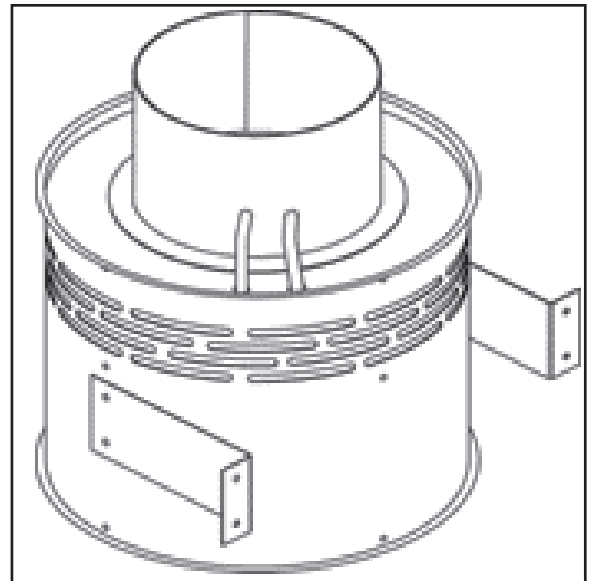

Figure 1

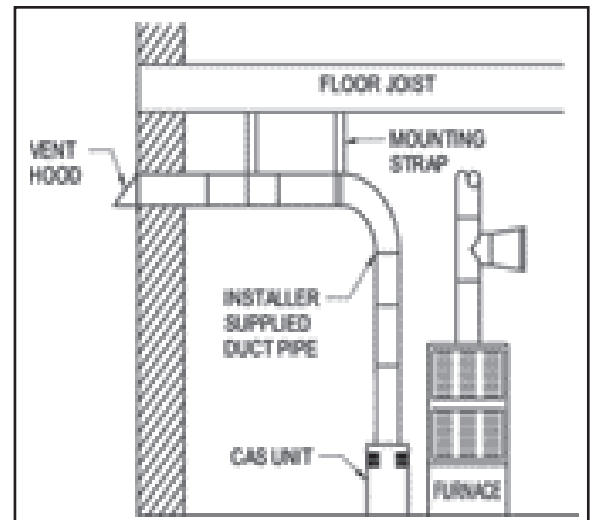

Figure 2



**WARNING! CONNECTIONS TO MULTIPLE APPLIANCES MUST FOLLOW INSTALLATION INSTRUCTION WIRING DIAGRAMS. FOR HELP CALL 1-800-742-8368.**

**WIRING INSTRUCTIONS**

Wire the CAS unit in accordance with the National Electric Code and applicable local codes. UNIT MUST BE GROUNDED. Check the ground circuit to make certain that the unit has been properly grounded. The wiring should be protected by an over-current circuit device rated at 15 amperes. CAUTION must be taken to ensure that the wiring does not come in contact with any heat source. All line voltage and control circuits between the CAS unit and the appliance MUST be wired in accordance with the National Electrical Code for Class I wiring or equivalent.

Remove the wiring access cover to access the wiring terminals. Use the enclosed conduit connector(s) to route the appropriate wires through the CAS housing. The incoming ground wire must be attached to the green colored ground screw near the wire terminals. The following sections describe the most common applications. The references to various series of control kits implies that any kit in that series may be used. If further information or additional wiring diagrams are needed please consult Field Controls' technical support.

**INTERNAL WIRING CONNECTIONS FOR THE CAS UNIT**

Refer to Figure 4 for the internal wiring of the CAS-4 unit.

**External Wiring Connections**

WIRE KEY	WIRE COLOR		
	W1	W2	W3
MOTOR MANUFACTURER	W1	W2	W3
McLean Engineering	Black	Blue	Brown
All Others	Brown	Black	Blue

Refer to Figures 5-12 for appropriate wiring method.

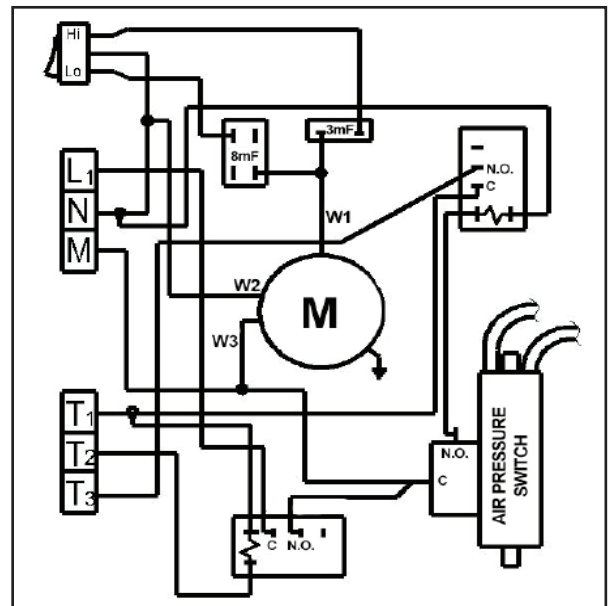

Figure 3

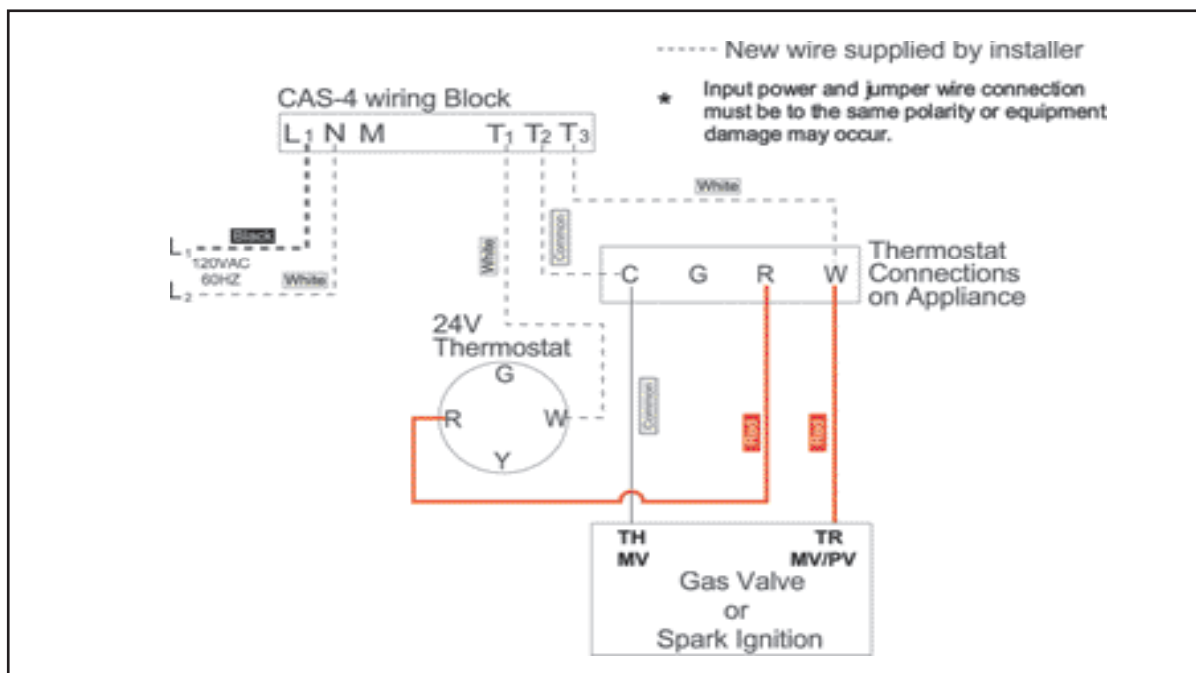

Figure 4- Chimney Vent Single 24V Furnace

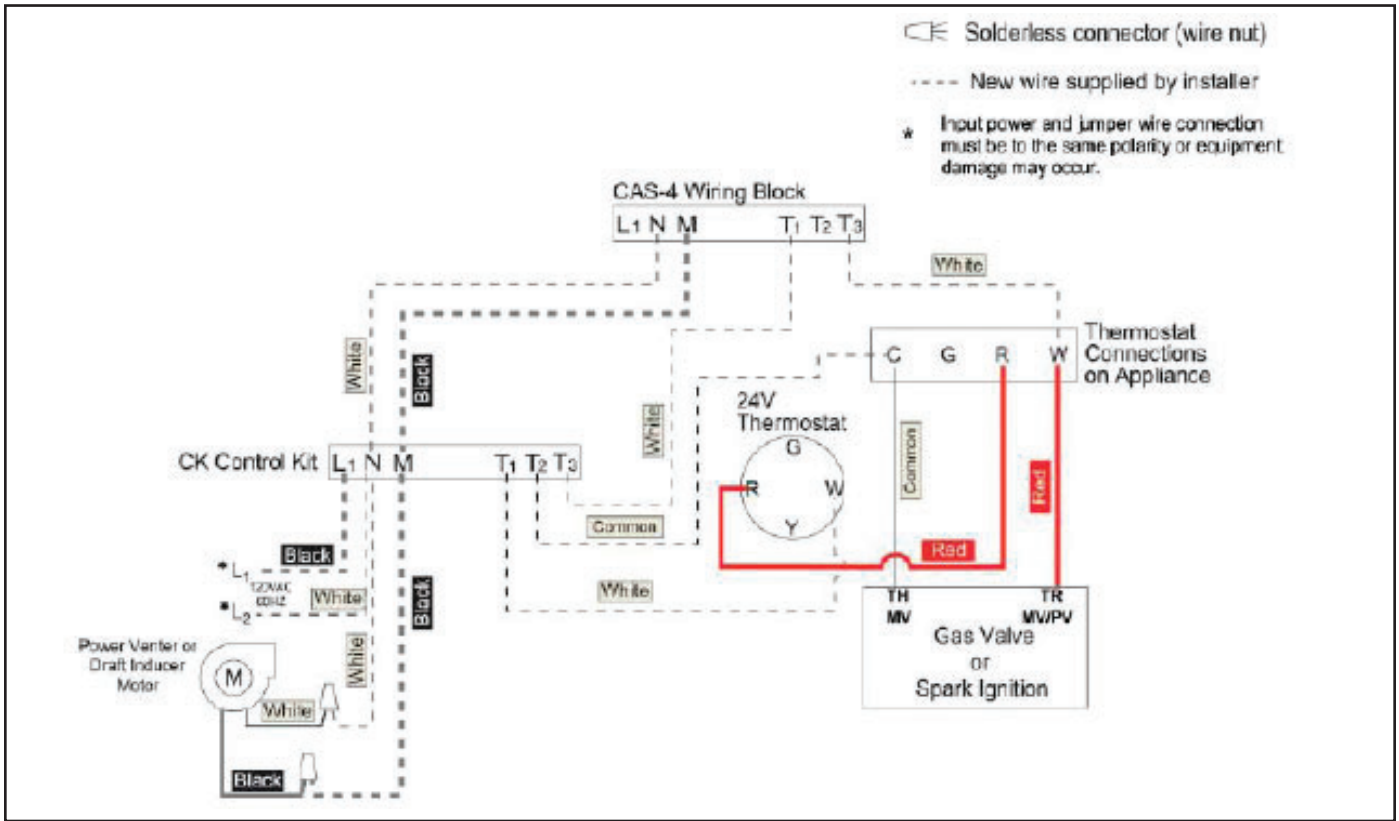

Figure 5- Power Vent Single 24V Furnace

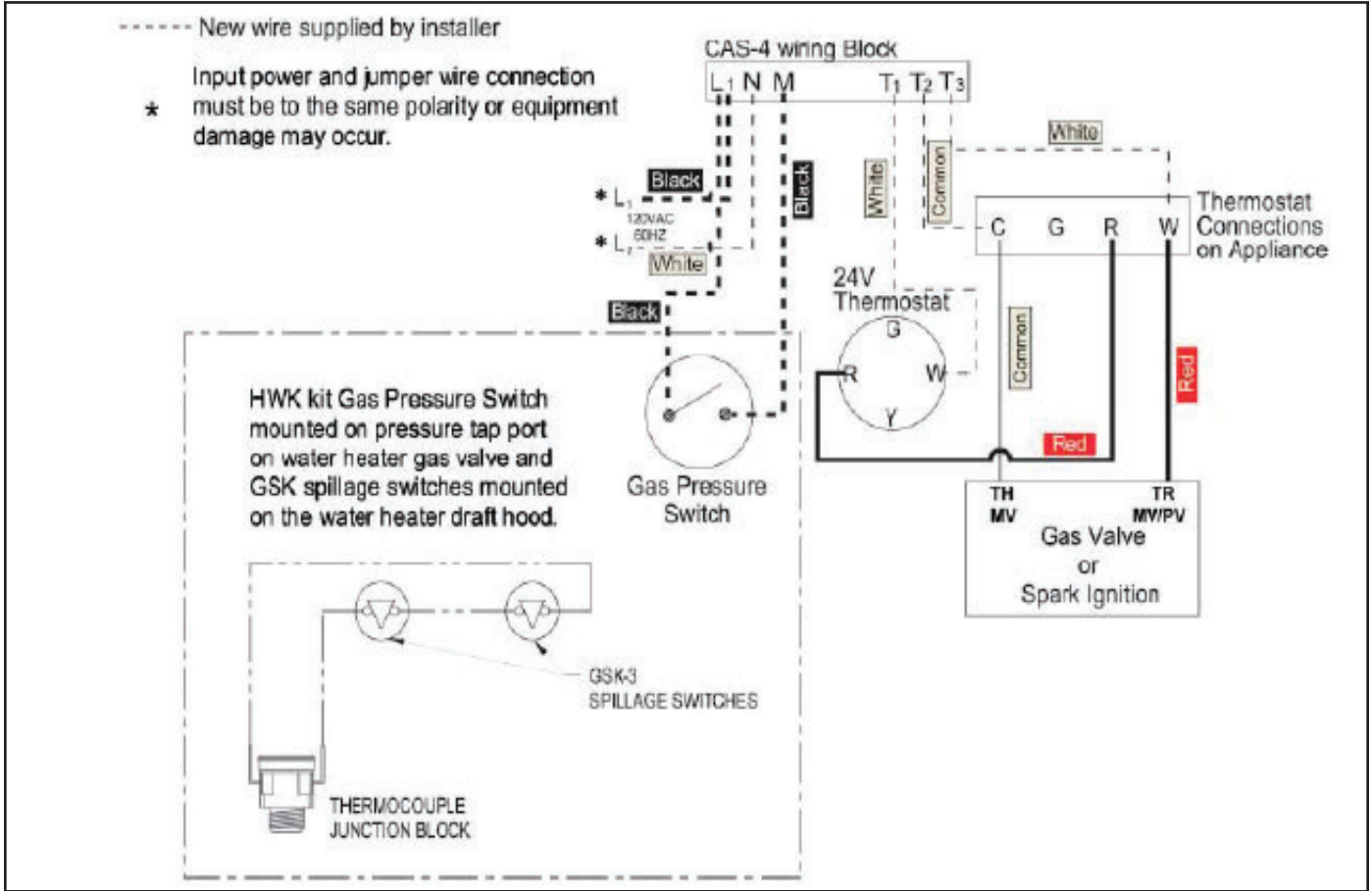

Figure 6- Chimney Vent 24V Furnace and 30mV Water Heater With CK-20FV or CK-20FG

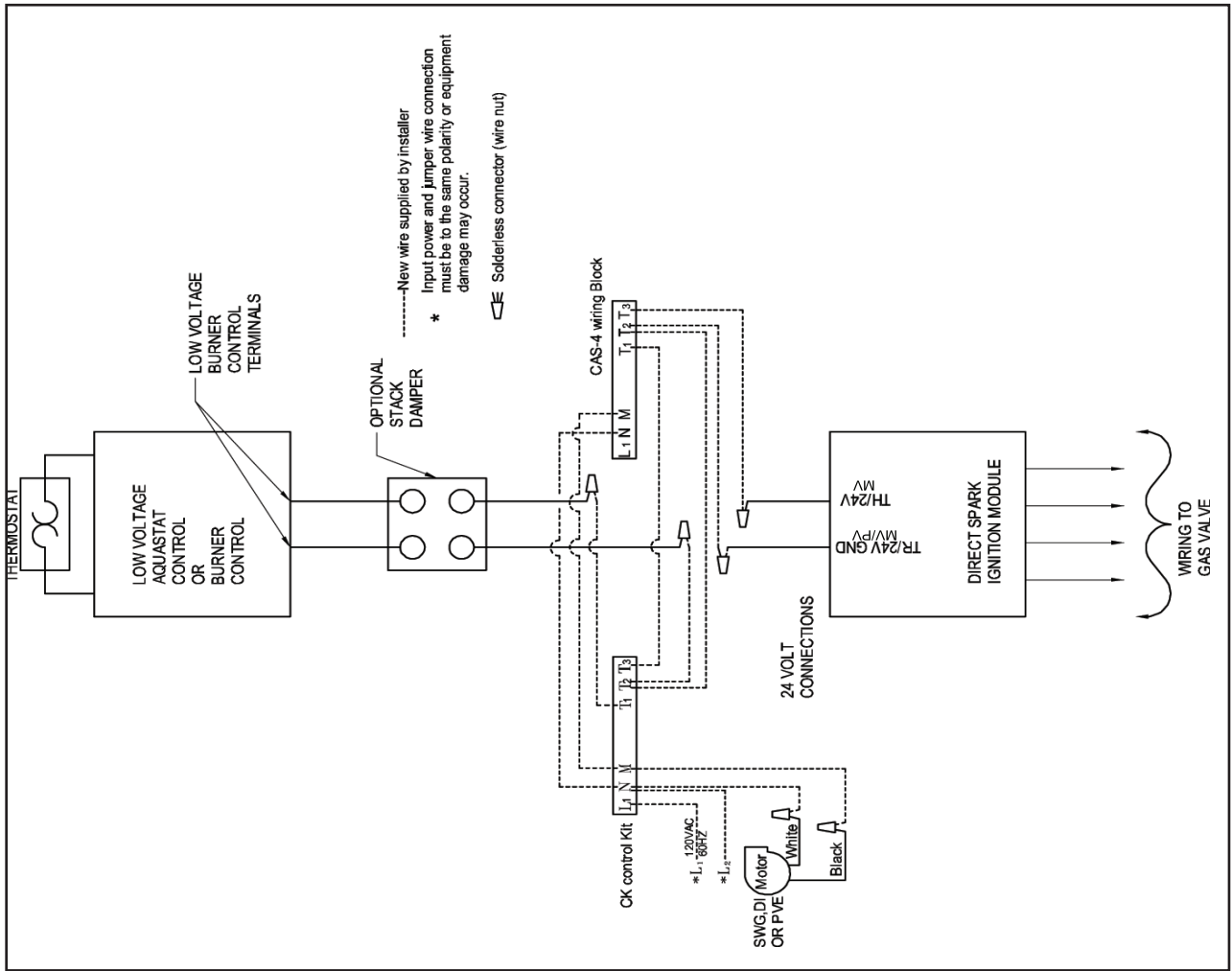

Figure 8 - Power Vent Single 24V Boiler

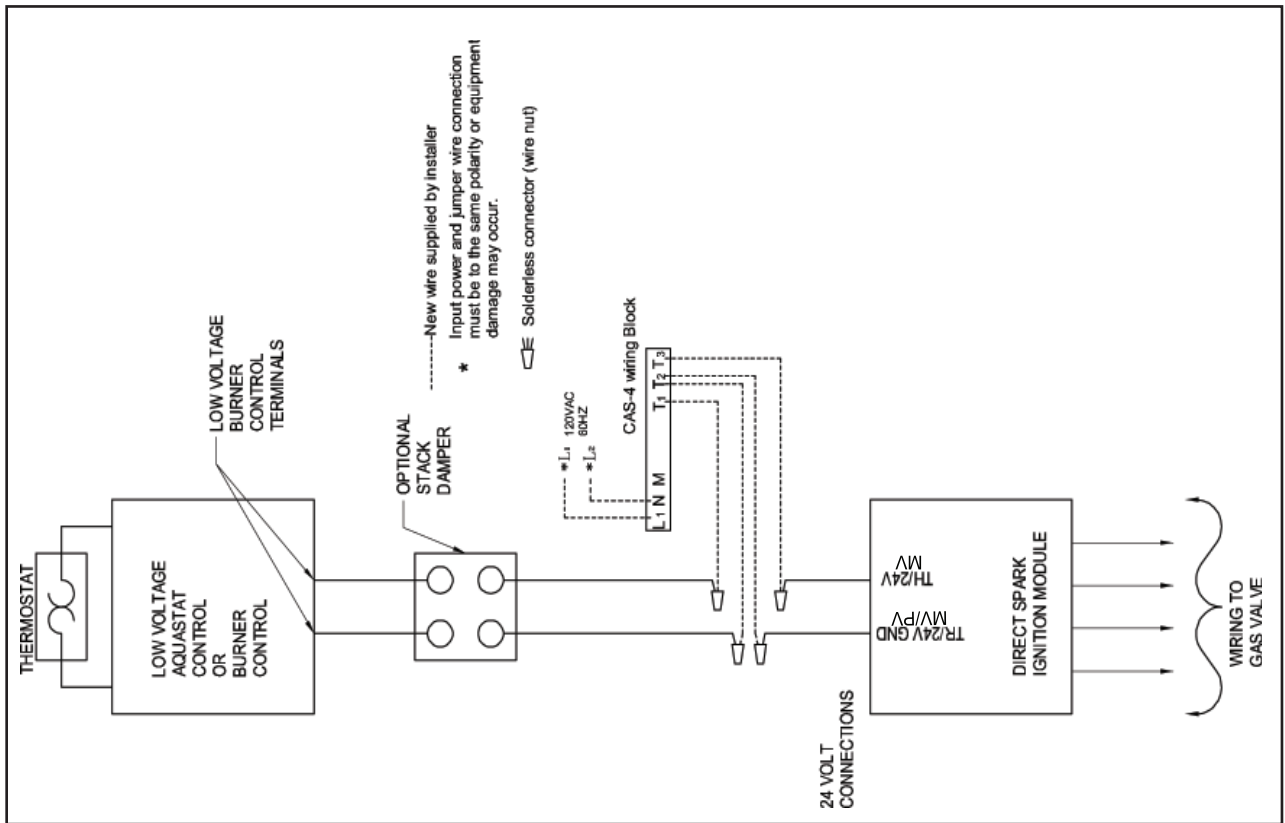

Figure 7 - Chimney Vent 24V Boiler



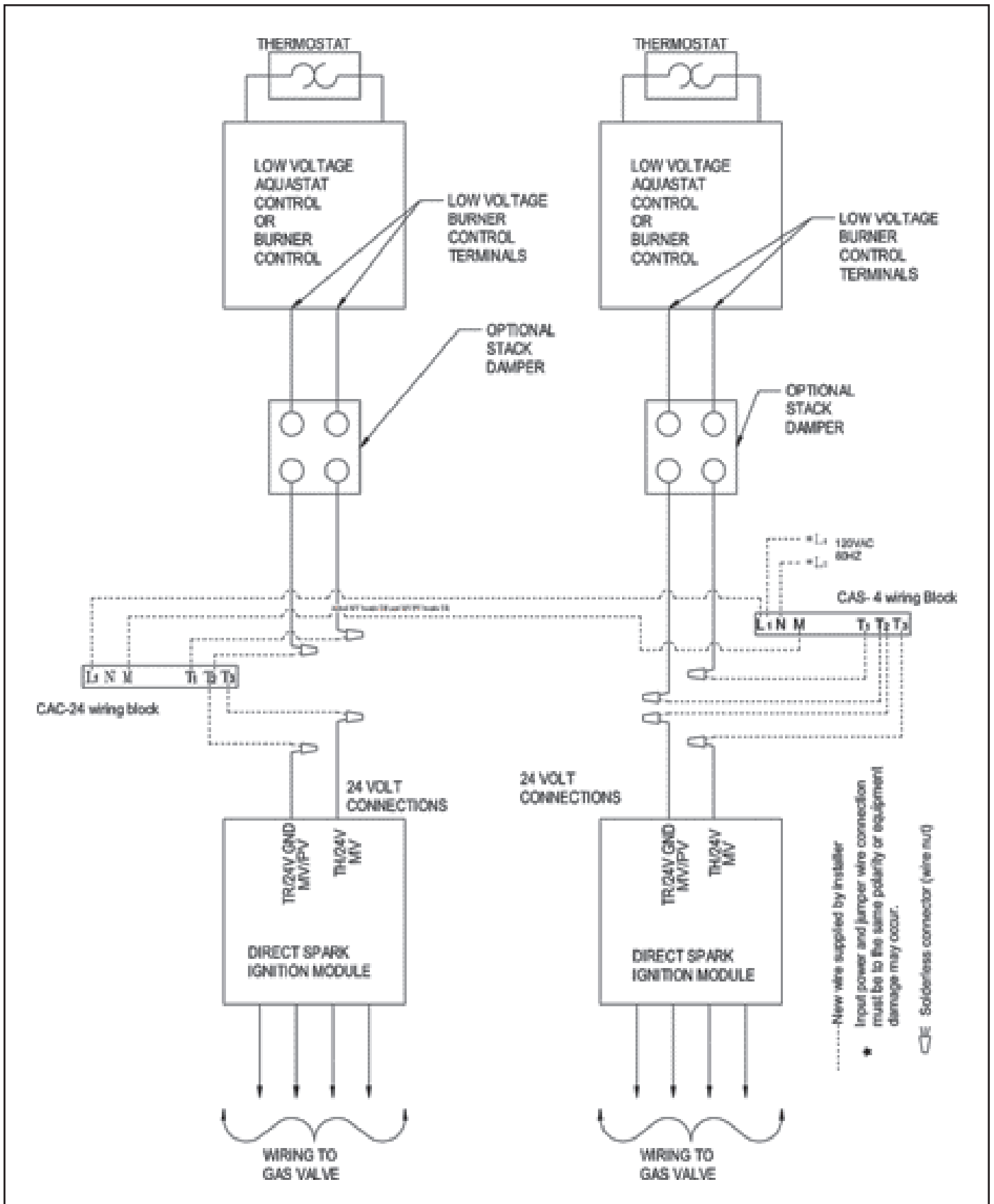

Figure 9 - Chimney Vent Two 24V Gas Appliances With CAC-24

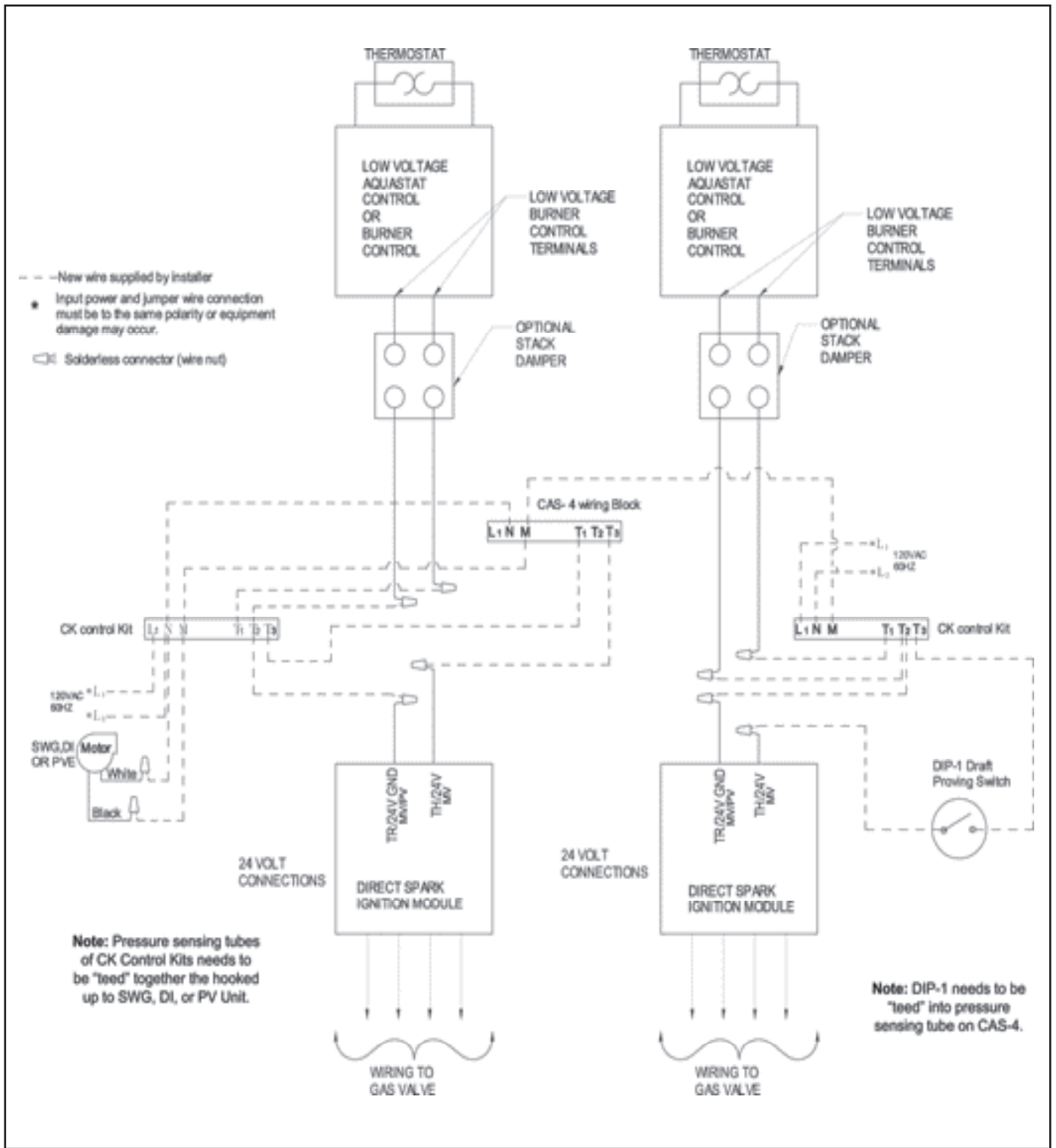

Figure 10- One Power Venter Two 24V Gas Appliances

## MAINTENANCE

1. Inspect the system annually to ensure proper operation by observing that the fan activates when a call for heat occurs and deactivates when the call for heat is satisfied.
2. Disconnect power to the CAS unit and repeat Step 1. Note: The unit should not run and the appliance should not fire in this condition.
3. Inspect the duct pipe for cracks and security to the CAS unit and vent hood. The CAS unit will not allow the appliance(s) to fire if inadequate air flow is allowed into the inlet of the CAS.
4. Clear any obstructions, if present, from the inlet of the vent hood and the outlet of the CAS unit.
5. Periodically, the fan blade chamber may need cleaning. First, disconnect the power supply to the CAS. Next, disconnect the duct pipe from the unit. Then remove the top pan and clean the fan housing area as needed. Reattach the top pan, reconnect the duct pipe and the power supply.

## REPLACEMENT PARTS

The following items are available for replacement, if needed. In order to replace these parts, power must be disconnected and the unit must be disassembled. If this is necessary, take note of the positions and locations of whatever items that may need to be removed to replace other items.

If in doubt, please consult Field Controls Technical Support at 1-800-742-8368.

ITEM DESCRIPTION	FIELD PART NUMBER
Motorized Fan	46274100
Pressure Switch Fxd for CAS-4TMR	511100200
24 VAC Relay for CAS-4	46161400
120 VAC Relay for CAS-3,4	46257300

This manual may be downloaded and printed from the Field Controls website ([www.fieldcontrols.com](http://www.fieldcontrols.com))

**WARRANTY**

For warranty information about this or any Field Controls product, visit:  
[www.fieldcontrols.com](http://www.fieldcontrols.com)

Field Controls Technical Support  
1.800.742.8368  
[fieldtec@fieldcontrols.com](mailto:fieldtec@fieldcontrols.com)



**FIELD CONTROLS**  
Phone: 252.522.3031 • Fax: 252.522.0214  
[www.fieldcontrols.com](http://www.fieldcontrols.com)