



INSTALLATION MANUAL



This symbol on the product means the PVE-1200 is tested by Intertek to meet safety and performance standards for the U.S. and Canada.

POWER VENTER

Model: PVE-1200

READ THESE INSTRUCTIONS CAREFULLY AND COMPLETELY BEFORE PROCEEDING WITH THE INSTALLATION

This device **MUST** be installed by a qualified agency in accordance with the manufacturer's installation instructions. The definition of a qualified agency is: any individual, firm, corporation or company which either in person or through a representative is engaged in, and is responsible for, the installation and operation of HVAC appliances, who is experienced in such work, familiar with all the precautions required, and has complied with all the requirements of the authority having jurisdiction. Please retain these instructions after installation.

THIS PAGE INTENTIONALLY LEFT BLANK

The Power Venter you have purchased has been designed to be simple to install, operate and maintain.
Read this manual before you install the power venter

This product should be installed according to local and national codes and standards.



Parts included in Power Venter package:

1. Power Venter



Replacement Parts:

1. PVE-1200 Motor (46226500)
2. PVE-1200 Blower Wheel (46124000)

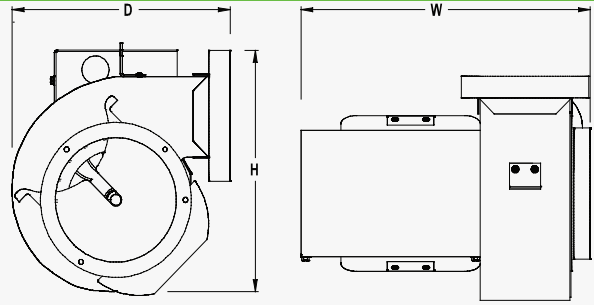

TABLE OF CONTENTS

Typical Venting System Components.....	5
Product Specifications.....	5
Sidewall Vent Hoods.....	5
Control Kits.....	6
System Operation.....	6
Power Venter Sizing.....	6 - 7
Installation Safety Instructions.....	8
Installation of Power Venter.....	9 - 10
Connecting Venter to Appliance.....	10
General Wiring Instructions.....	11
Adjusting Thermostat Anticipator.....	11
Air Flow Adjustments.....	12
General Installation Inspection.....	13
Maintenance.....	13
Initial Burner and Venting System Operational Information.....	14

TYPICAL VENTING SYSTEM COMPONENTS

1. PVE-1200 Power Venter
2. SWH Series Sidewall Vent Hood (Not Included)
3. CK Series Control Kit (Not Included)



SPECIFICATIONS

MODEL	UNIT DIMENSIONS (INCHES)				ELECTRICAL DATA					
	H	W	D	INLET/ OUTLET	VOLTS	HZ	RPM	WATTS	AMPS	THERMAL PROTECTION
PVE-1200	13.75	12.50	13.50	8.00	120	60	1725	280	2.5	YES

SIDEWALL VENT HOODS

Sidewall vent hoods are available in the sizes listed below. The vent hood should be chosen that matches the outlet size of the Power Venter.

Note: Different sizes may be used as long as the reducers and specific size pipe are considered when determining equivalent length of vent pipe.

SWH-8 = 8"

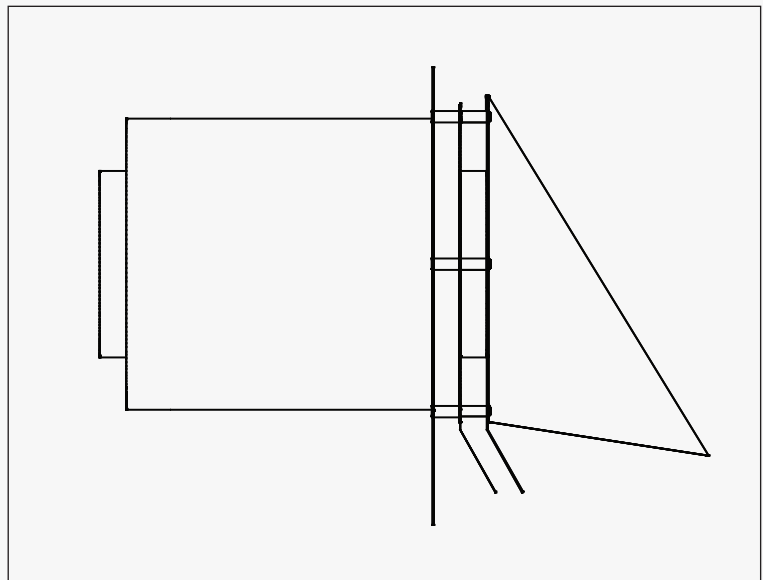

Figure 1 - Typical Side Wall Vent Hood



INSTALLATION SAFETY INSTRUCTIONS

CAUTION: This device must be installed by a qualified installer in accordance with the manufacturer's installation instructions. Appliances should have a minimum of 75% combustion efficiency or have a maximum measured flue gas temperature of 550°F at the inlet of the venter.

1. The power venter system must be installed by a qualified installer. "Qualified Installer" shall mean an individual who has been properly trained or a licensed installer. The installer must write or imprint his/her name, phone number, and date of installation on the installation tag. The tag should be attached to the power venting system control kit box or venter unit. Recording burner and venting system initial operational information is recommended as a guide for services or burner tune-up. Enter this information in the spaces provided at the end of this manual.
2. Safety inspection of a venting system should be performed before and after installing a power venting system on an existing or new appliance. Procedures to follow are those recommended by the National Fuel Gas Code, ANSI Z223.1 or refer to the "General Installation Inspection" section of this manual.
3. Plan the vent system layout before installation to avoid the possibility of accidental contact with concealed wiring or plumbing inside walls.
4. Single wall vent pipe may be used to join an appliance to the venting system, but if proper clearances cannot be maintained from combustible materials, Class B Vent Pipe should be used for gas appliances and Class L Type Vent Pipe for oil appliances. Refer to national or local codes for guidelines.
5. Disconnect power supply before making wiring connections to prevent electrical shock and equipment damage.
6. This equipment is designed to overcome minor negative pressure conditions. To ensure extreme negative pressure does not exist, follow the "General Installation Inspection" section of this manual.
7. Heating appliances equipped with draft hoods, such as boilers or furnaces, LP and natural gas appliances, SHOULD have a secondary spillage switch installed. On appliances without draft hoods, it is recommended that the secondary safety switch WMO-1 be installed into the system. Gas-fired 30 millivolt power system MUST be equipped with a spillage switch.
8. Air flow adjustments MUST be made to ensure appliance efficiency. This should be done at the appliance exhaust outlet with a velocity meter, draft gauge or by the "match test procedure". The match test is in accordance with National Fuel Gas Code ANSI Z223.1, Section 8.6.
9. On oil-fired and gas-fires heating appliances not equipped with a draft hood, a barometric damper control MUST be installed to regulate proper air flow and fluctuations in the system's air flow during operation. Fluctuations can come from wind loads on the outlet of the venter, house depressurization during windy days, and the different house ventilation requirements between summer and winter operation. For gas appliances use a Field Controls Type MG-1 Barometric Draft Control. For oil appliances use a Field Controls Type M or RC Barometric Draft Control. Gas-fired draft induced systems should have a single-acting or double-acting barometric draft control installed.



INSTALLATION OF POWER VENTER

CAUTION: Failure to install, maintain, and/or operate the power venting system in accordance with manufacturer's instructions will result in conditions which may produce bodily injury and/or property damage.

1. Remove power venter from box and inspect unit for damage. If the carton has been crushed or mutilated, check unit very carefully for damage. Rotate venter wheel to insure that the motor and venter wheel rotate freely. DO NOT install if damage is apparent. Refer to unit sizing to check proper venting sizing.
2. Location of the termination of the venting system should be installed in accordance with the National Fuel Gas Code, ANSI Z233.1, manufacturer's recommendations, and/or local codes which are applicable. See the following requirements or refer to Diagram A for typical installation locations.
 - A. The exit termination of mechanical draft systems shall not be less than 7' above grade when located adjacent to public walkways.
 - B. A venting system shall terminate at least 3' above any forced air inlet located within 10'.
 - C. The venting system of other than a direct vent appliances shall terminate at least 4' below, 4' horizontally from, or 1' above any door, window, or gravity air inlet into the building.
 - D. The vent termination of a direct vent appliance with an input of 50,000 BTU/HR or less, shall be located at least 9" from any opening through which vented gases could enter the building. With an input of 50,000 BTU/HR, a 12" termination clearance shall be required.
 - E. The vent termination point shall not be installed closer than 3' from an inside corner of an L-shaped structure.
 - F. The vent termination should not be mounted directly above or within 3' horizontally from an oil tank vent or gas meter.
 - G. The bottom of the vent terminal shall be located at least 12" above finished grade.

NOTE: If mounting the power venter through a combustible wall material, a minimum clearance of 1/2" must be maintained between the venter outterpipe and combustible materials.

3. The power venter should never be installed with the venter motor in the vertical position. This could lead to premature motor failure. The venter outlet can be oriented at any angle, from horizontal to vertical. The power venter should be installed as close to the outside wall as possible.

CONTROL KITS



The following are the most commonly used Control Kits.

- CK-20FV:** For operation with 30 millivolt or 750 millivolt gas-fired water heaters, gas-fired space heaters and gas-fired pool or spa heaters with an internally mounted thermostat. Includes a non-adjustable post purge timer.
- CK-41F:** For operation with gas-fired furnaces, boilers, unit heaters and water heaters operating with a 24 VAC gas valve.
- CK-63:** For operation with all 120VAC oil-fired systems. Includes draft proving switch, adjustable electronic post purge timer, and WMO-1 secondary safety switch.
- CK-92FV:** For operation with a draft induced gas-fired furnace or boiler and a 30-millivolt operated water heater. Includes an adjustable post purge relay/timer and a draft control. Use the CK-92FV for draft hooded appliances. Use the CK-92FV for a non-adjustable post purge relay/timer.

SYSTEM OPERATION

1. The thermostat (wall thermostat, or aquastat) calls for heat and energizes a relay which activates the power venter. After the venter motor has come up to speed, the pressure switch closes. This completes the circuit to the burner and allows the burner to fire.
2. For millivolt controlled water heaters, the gas pressure switch on the gas valve activates the power venter at the same time as the burner fires.
3. After the heating requirements has been satisfied, the thermostat circuit will open and deactivate the burner and power venter circuit.
4. For venting systems equipped with a post purge device, the power venter operates for a period of time after the burner has shut off to purge remaining flue gases.

POWER VENTER SIZING

In order to choose the correct size power venter for a particular installation, the total input firing rate and total equivalent length of vent pipe to be used must be known. Refer to the following sizing chart to determine the maximum allowable equivalent feet of pipe. When venting multiple appliances, add the input of each appliance to determine the total input. Always choose a power venter that is capable of handling more than the system requires. The choke plate can be adjusted to compensate for the difference.



POWER VENTER SIZING - CONTINUED

MAXIMUM EQUIVALENT HORIZONTAL PIPE LENGTH (FEET)		
BTU/HR INPUT	VENTER MODEL AND VENT PIPE DIAMETER	
	8"	10"
25,000	-	-
55,000	-	-
70,000	-	-
100,000	-	-
145,000	-	-
220,000	-	-
310,000	-	-
400,000	-	-
520,000	443	-
610,000	313	390
700,000	227	330
900,000	180	290
1,000,000	125	190
1,250,000	-	80

PROCEDURE FOR CALCULATING TOTAL EQUIVALENT PIPE LENGTH IN FEET

1. Calculate the total equivalent feet for each type of fitting used in the venting system from the chart below.
2. Calculate the total amount of feet for the straight lengths of vent pipe.
3. Add the equivalent feet for the fittings with the total amount of feet of straight lengths.

EQUIVALENT LENGTH (FEET) OF VENT PIPE FOR VENT FITTINGS				
VENT PIPE FITTINGS		VENT PIPE DIAMETER		
		8"	9"	10"
TEE		50	56	63
90° ELBOW		14	16	18
45° ELBOW		7	8	9
REDUCER (d/D)*	¼	22	25	28
	½	13	15	17
	¾	5	6	6

- Reducer or increaser ratio (d/D) small diameter divided by the larger diameter. Example 4" to 8" reducer, the reducer ratio is $d/D = 4/8 = 1/2$. To estimate the equivalent foot length for the fitting, use the smaller pipe diameter for the equivalent length figure. Example 4" to 8" reducer; the reducer ratio is 1/2 and the smaller pipe diameter is 4". So, from the chart the equivalent feet would be 7 feet.

Example:

System Pipe Size = 4

Step 1 Two 4" -90° Elbows = 14 ft.

Step 2 Ten 2 Ft. Lengths of 4" Pipe = 20 ft.

Step 3 Total Equivalent Feet = 14 ft + 20 ft = 34 ft

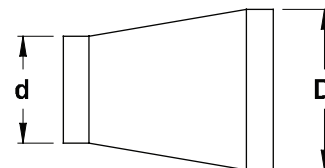

Figure 3: Typical Pipe Fitting



INSTALLATION OF POWER VENTER

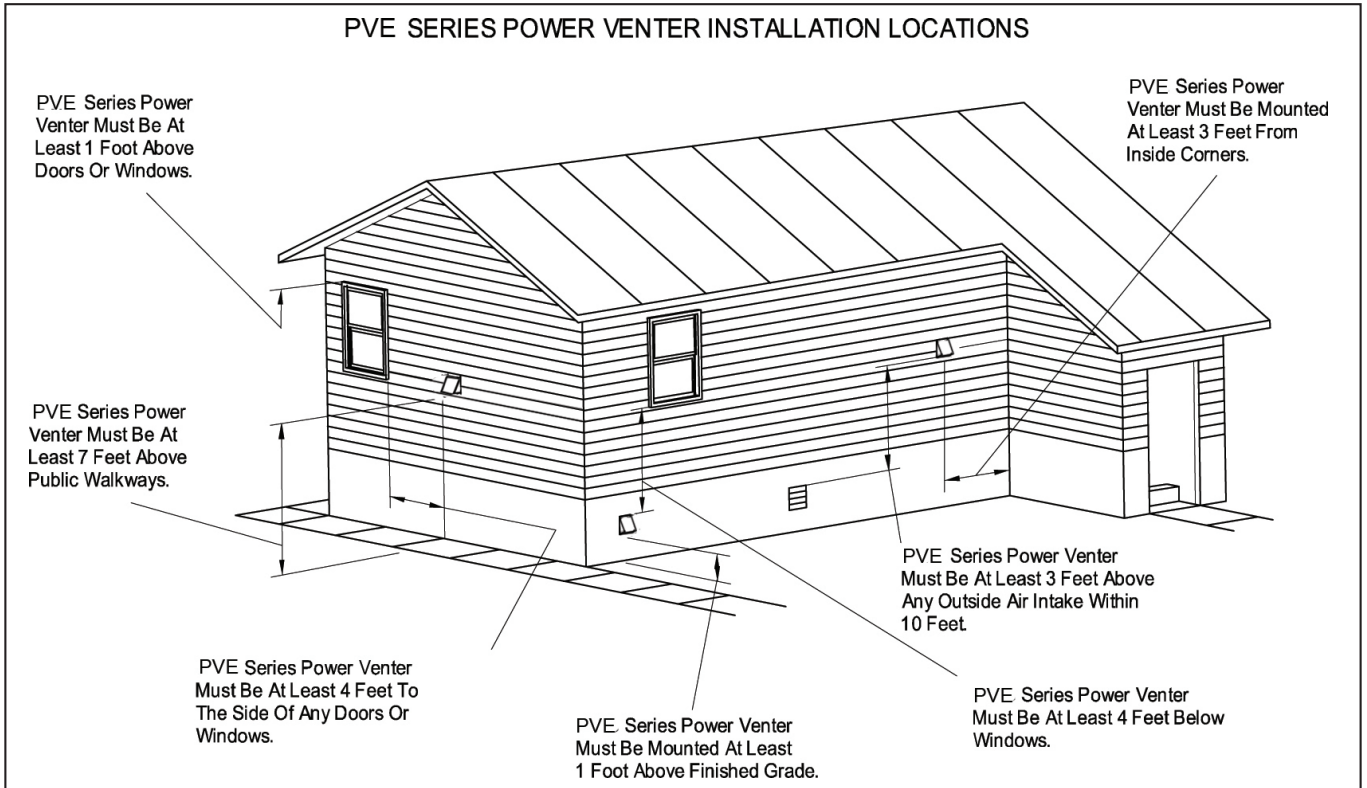

Diagram A: PVE Sidewall Vent Termination Locations

CONNECTING VENTER TO APPLIANCE

The venting system should be installed and supported in accordance with the National Fuel Gas Code ANSI Z223.1, or in accordance with any local codes. A vent pipe connector shall be supported for the design and weight of the material employed, to maintain clearances, prevent physical damage and separation of joints. A vent pipe increaser or reducer may be required for connecting the venter to the vent system. Smaller vent pipe sizes than a chimney-vented system may be used for the vent system.

Route the vent pipe from the appliance to the venter using as few elbows as possible. The horizontal section of the vent pipe should have a slight upwards slope from the appliance to the venter. For clearances to combustibles materials, multiple appliance venting and other installation requirements, refer to the National Fuel Gas Code ANSI Z223.1, and/or any applicable local codes, or appliance manufacturer's installation instructions.

**CONTROL
WIRING
SOLUTIONS**





GENERAL WIRING INSTRUCTIONS

The PVE-1200 is designed to be used with either millivolt, 24 VAC, or 120 VAC appliances when used with the appropriate controls. For use on a millivolt controlled system, a Field controls Control Kit. For use on a 24 VAC or 120 VAC controlled system a Control kit must be used. The small steel tube mounted on the inlet of the PVE power venter must be connected to the air pressure switch on the Control Kit. This enables the primary safety feature of the PVE power venter system.

Wire the venter motor and controls in accordance with the National Electric Code, and/or applicable local codes. UNIT **MUST BE GROUNDED**. Check ground circuit to make certain that the unit has been properly grounded. The wiring should be protected by an over-current circuit device rated at 15 amperes. **CAUTION MUST** be taken to ensure that the wiring does not come in contact with any heat source. All line voltage and safety control circuits between the venter and the appliance **MUST** be wired in accordance with the National electrical Code for Class 1 wiring, or equivalent methods.

ADJUSTING THERMOSTAT ANTICIPATOR

If connecting the Power Venter system to a gas appliance with a thermostat anticipator, refer to the following to make adjustments.

1. Disconnect on side of the thermostat circuit at the gas valve or burner control, and connect an ampere meter into the circuit. With the system running, take an amperage reading on the circuit.
2. Check the nameplate or instructions for the thermostat to obtain the proper amperage level. Adjust amperage level by moving the anticipator lever.
3. Reconnect the thermostat to the gas valve and start the system operation.
4. Time the burn cycles and adjust as follows; To make the cycle time longer, increase the amount on the anticipator (Example: .45 to .5 Amps); to decrease cycle time, reduce the amount on the anticipator (Example: .45 to .3 Amps) (See Figure 4)

GENERAL INSTALLATION INSPECTION

Recommended procedures for safety inspection of an appliance in accordance with the National Fuel Gas Code ANSI Z223.1. The following procedure will help evaluate the venting system. It is intended as a guide to aid in determining that the venting system is properly installed and is in a safe condition for continuous use. This procedure should be recognized as a generalized procedure which cannot anticipate all situations. Accordingly, in some cases, deviation from this procedure may be necessary to determine safe operation of the equipment. If it is determined that a condition exists which could result in unsafe operation, the appliance should be shut off and the owner advised of the unsafe condition. Corrections must be made before the appliance is put into continuous operation. The following steps should be followed in making a safety inspection.

1. Visually inspect the venting system for proper size and determine that there is no flue gas spillage, blockage or restriction, leakage, corrosion, or other deficiencies which could cause an unsafe operation.
2. As far as practical, close all building doors, fireplace dampers, windows, and all doors in area in which the appliance is located. Turn on clothes dryer and any exhaust fans, such as range hoods and bathroom exhausters, so they operate at maximum speed. Do not operate a summer exhaust fan. If, after completing Steps 3 through 7, it is believed sufficient combustion air is not available, refer to the National Fuel Gas Code ANSI Z223.1, or any applicable local codes for guidance.
3. Place in operation the appliance being inspected. Follow the lighting instructions and adjust thermostat so appliance will operate continuously.
4. Determine that the pilot or burner is operating properly and that the main burner ignition operates satisfactorily, by interrupting and re-establishing the electrical power of the appliance in any convenient manner. Test the pilot or burner safety device to determine if it is operating properly by extinguishing the pilot or disconnecting the flame safety circuit and pressure switch sensing tube from pressure switch.
5. Visually determine that the main burner is burning properly; i.e., no floating, lifting, or flashbacks. Perform a smoke test on oil-fired system; the burner should operate at a zero to trace smoke. This can indicate reduced available combustion air to burner.
6. If appliances are equipped with high and low flame control, or flame modulation, check for proper main burner operation at low flame.
7. Test for spillage at draft hood or barometric draft control opening and burner inlet air location after 5 minutes of main burner operation. Use a draft gauge, flame of a match or candle, smoke from a cigarette, cigar or pipe. If spillage occurs, adequate air is not available. Shut off heating appliance thermostat and check for spillage around the draft hood, barometric draft control, or burner inlet air location after power venter has stopped operation. If a flow reversal is noticed, house depressurization is occurring and make up air is required. For oil-fired systems, this may be noticed by oil fume smell after post purge cycle.
8. Turn on all fuel burning appliances within the same room so that they will operate at their maximum input. Then repeat steps 5 through 7.
9. Return doors, windows, exhaust fans, fireplace dampers, and any other fuel-burning appliances to their previous condition of use.

MAINTENANCE

1. Motor: Inspect the motor once a year. Motor should rotate freely.
2. Wheel: Inspect the venter wheel annually to clear any soot, ash, or coating which inhibits either rotation or air flow. Remove all foreign materials before operating.
3. Vent System: Inspect all vent connections annually for looseness, for evidence of corrosion, and for flue gas leakage. Replace, seal, or tighten pipe connections if necessary. Check the power venter choke plate to ensure it is secured in place. Check the barometric draft control, if installed, to ensure the gate swings freely.
4. System Safety Devices: With the heating system operating, disconnect the pressure sensing tube from the pressure switch on the Control Kit. This should stop the burner operation. Reconnecting the tube will relight the burner. For 30 millivolt operating systems, disconnect one lead of the spill switch circuit from the thermocouple junction block. This should shut off the pilot and the burner. Re-connection will allow relighting the pilot.

INITIAL BURNER AND VENTING SYSTEM OPERATIONAL INFORMATION

List for each operating appliance on the sidewall venting system, as a guide for tune-up or service information.

FOR GAS-FIRED EQUIPMENT

Heating Appliance BTU/HR Input _____

Gas Valve Operation Pressure _____

Vent System Draft Above Draft Hood _____

or Below Barometric Draft Control _____

CO₂ Measurement _____

CO Measurement _____

Equipment Outlet Flue Gas Temperature _____

FOR OIL-FIRED EQUIPMENT

Oil Burner Nozzle Size _____

Oil Burner Operating Pressure _____

Pump Operating Vacuum Pressure _____

Smoke Number _____

Over-fire Draft _____

Equipment Outlet Flue Gas Temperature _____

CO₂ Measurement _____

THIS PAGE INTENTIONALLY LEFT BLANK

This manual may be downloaded and printed from the Field Controls website (www.fieldcontrols.com)

WARRANTY

For warranty information about this or any Field Controls product, visit:
www.fieldcontrols.com/ventCool

Field Controls Technical Support
1.800.742.8368
fieldtec@fieldcontrols.com



FIELDCONTROLS

Phone: 252.522.3031 • Fax: 252.522.0214
www.fieldcontrols.com



AIR FLOW ADJUSTMENTS

1. To adjust the power venter air flow, open the choke plate $\frac{1}{2}$ to $\frac{3}{4}$ of the way open (See Figure 5). Follow appliance manufacturer's procedures for starting the heating appliance. Then adjust the thermostat to call for heat.
2. After the system has operated for several minutes to stabilize flue gas temperatures, check for negative draft or up-draft at the heating appliance outlet or air flow into the draft hood.
3. Use a draft gauge, velocity meter, or match test procedure.
4. Adjust the inlet choke damper on the power venter in or out to obtain the minimum air flow required to maintain draft.
5. Then increase air flow slightly (10% over minimum air flow rate) to ensure proper venting. For oil-fired or gas-fired power burners, adjust to proper over-fired draft. If using a barometric draft control, use the draft control to fine tune the system draft.
6. If proper draft has been established, secure the choke plate by tightening the screws on the inlet collar. For gas-fired systems, shut off thermostat and check for residual heat spilling from the draft hood. If this occurs, a post purge system may be required. If so, use a Field Controls PPC-5 Electronic Post Purge.
7. Before installing, refer to the General Installation Inspection to check for negative pressure problems in the building. Refer to the appropriate control kit installation instructions for pressure switch adjustment procedure and system checkout procedures before operating continuously

NOTE: After proper venting has been established, it is recommended that a combustion test on gas and oil units, a check for CO level on gas units, and a smoke test on oil systems be performed to ensure maximum burner efficiency. Oil burner air adjustments should be set at a zero to trace smoke at the highest or recommended CO₂% setting set by the heating equipment manufacturer.

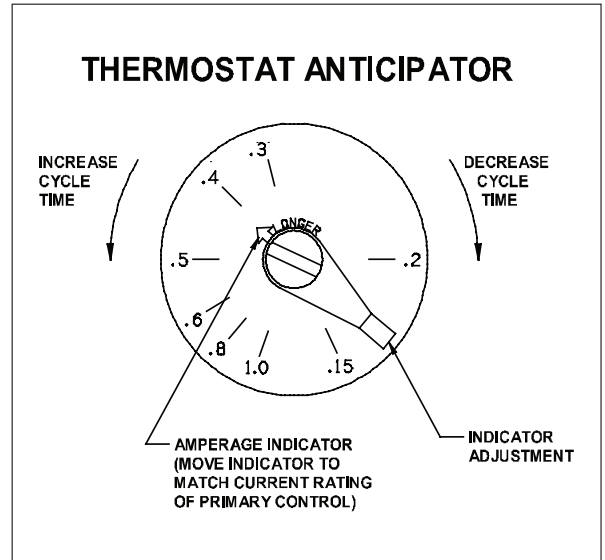

Figure 4

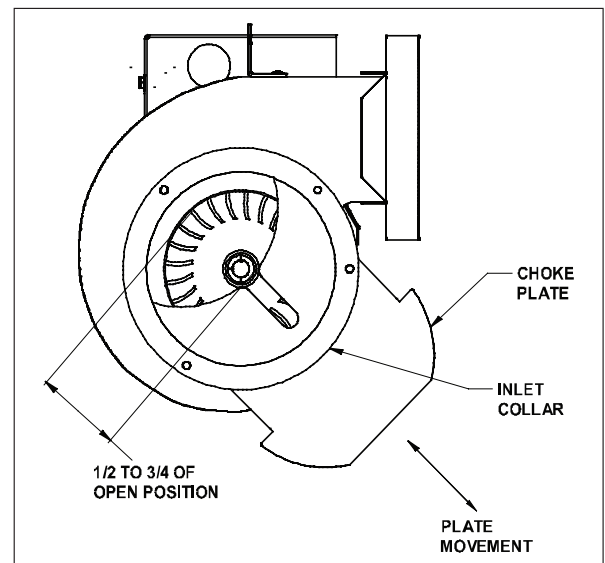

Figure 5