



INSTALLATION MANUAL



This symbol on the product means the UV-17FM is listed by Underwriters Laboratories, Inc

UV-AIRE™ AIR PURIFYING SYSTEM

Model: UV-17FM

READ THESE INSTRUCTIONS CAREFULLY AND COMPLETELY BEFORE PROCEEDING WITH THE INSTALLATION

This device MUST be installed by a qualified agency in accordance with the manufacturer's installation instructions. The definition of a qualified agency is: any individual, firm, corporation or company which either in person or through a representative is engaged in, and is responsible for, the installation and operation of HVAC appliances, who is experienced in such work, familiar with all the precautions required, and has complied with all the requirements of the authority having jurisdiction. Please retain these instructions after installation.

THIS PAGE INTENTIONALLY LEFT BLANK

The Air Purifying System you have purchased has been designed to be simple to install, operate and maintain. Read this manual before you install the air purifying system.

This product should be installed according to local and national codes and standards.

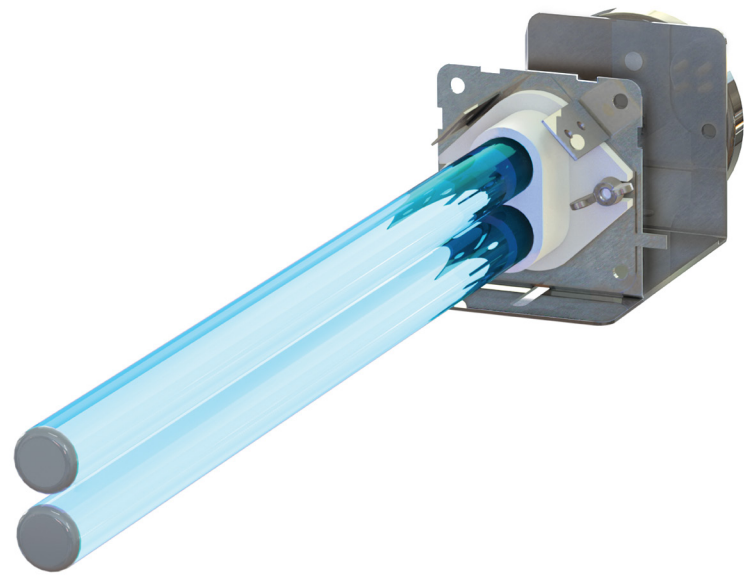

Parts included in Air Purifier System package:

1. Twin-Tube High-Output UVC Lamp
2. 24 VAC Ballast* (UL Listed) with Lamp Cable and connector
3. Articulating Bracket Assembly with Magnet
4. Reflective Shield
5. Snap-In Safety Viewport
6. UV Hazard Warning Label
7. Alcohol Wipe for Lamp
8. Hardware for Various Mounting Options
9. Installation Manual

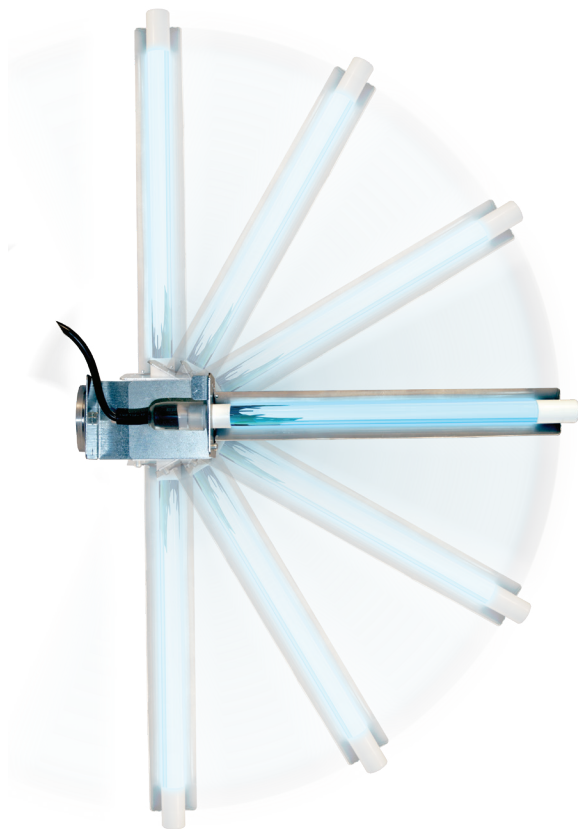

Options and additional parts recommended:

1. UV-17FM requires minimum of 50VA, 24VAC input power.

Field Controls Offers 50VA,24VAC output/multiple input 120/208/240 vac multiple mount transformer

Replacement Parts:

1. 17" Twin Tube Replacement Lamp (46632517)
2. Remote Ballast (46635900)
3. 50VA Multi Mount Transformer (46638900)

TABLE OF CONTENTS

Safety Considerations.....5
General Information.....5
Product Specifications.....5
Magnet Mount Installation Inside Plenum or Air Handler.....6
Internal Mount Installation Inside Plenum or Air Handler.....7 - 8
Bracket Mount Installation Through A-coil Delta Plate or Plenum.....9 - 10
Maintenance.....11
Lamp Replacement Procedure.....11
Troubleshooting.....11
Appendix A: Sizing Information for Coil Irradiation Applications.....12
Appendix B: Sizing Information for Air Disinfection Applications.....12

WARNING

- **Never expose eyes or skin to UVC light from any source.**
 - Looking directly at the UVC light may cause permanent eye damage or blindness.
 - Never operate the UV-Aire™ Air Purifying System out of the plenum.
 - Designed for a closed duct system. **DO NOT** mount near a supply or a return air opening.
- **UV light will break down plastic material not rated for UV exposure. (Examples: wire, insulation, flex duct, drain pans, and humidifiers)**
 - The unit must be mounted at least 30” from the above stated type of materials.
- If it is necessary to mount the unit in direct line of sight of these types of materials, they must be shielded with aluminum foil, aluminum foil tape, or sheet metal.
- **DO NOT** install this equipment outdoors except within a package unit air handler that is fully protected from moisture entry.

INDICATION FOR USE

This product is not sold as a medical device and is not for the purpose of diagnosis of any disease or condition nor for use in the mitigation, treatment, or prevention of any disease or condition.

GENERAL INFORMATION

The UV-Aire™ system is provided with a unique patented, magnetically-attached Mounting Bracket Assembly. The mounting bracket assembly may be rotated and/or extended relative to the mounting surface, to provide maximum flexibility in mounting positions and configurations.

A reflective aluminum shield is included which may optionally be used to shield wiring, ductwork, and parts which could be damaged by UVC exposure, and/or concentrate the UVC rays in a particular area such as the A-coil.

The part of the lamp bracket to which the lamp is attached may be separated from the mounting bracket assembly, and used for mounting the lamp through a delta plate covering the end of the A-coil, or for mounting the lamp inside of a plenum or air duct.

PRODUCT SPECIFICATIONS

| FLEXMOUNT UV | | | | | | | | | |
|--------------|---------|------|-------|-----------------------------------------|-----------------------------------------|------------------------------------------|-----------------|--------------------------|--------------|
| Model | Voltage | Amps | HZ | Lamp Intensity | | | Max Air Temp °F | Recommended HVAC Tonnage | Lamp Wattage |
| | | | | ($\mu\text{W}/\text{cm}^2@1\text{m}$) | ($\mu\text{W}/\text{cm}^2@1\text{m}$) | ($\mu\text{W}/\text{cm}^2@0\text{in}$) | | | |
| UV-17 | 24 | 1.9 | 50/60 | 110 | 13,970 | 38,940 | 190° | 1.5 to 5.0 | 36 |

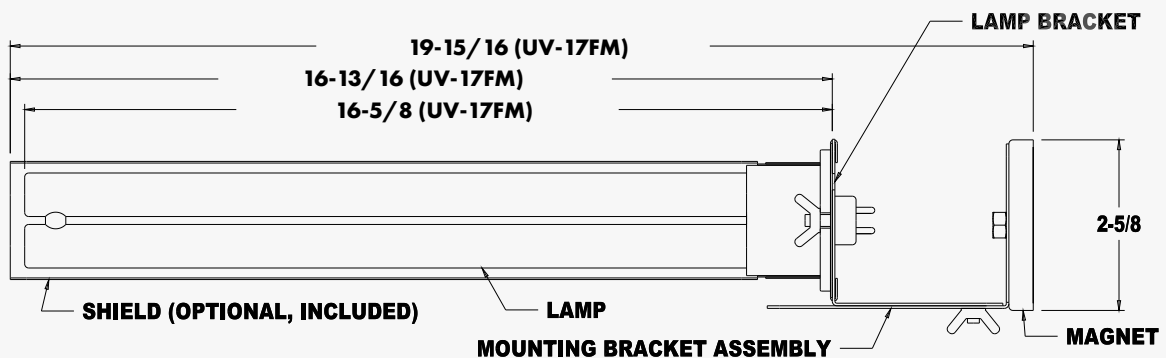

MAGNET MOUNT INSTALLATION INSIDE PLENUM OR AIR HANDLER



WARNING: Before installing or servicing a humidifier, air filter, heat system, or this unit, etc., always turn all power OFF and have unit unplugged. Electrical shock can cause personal injury or death. Never expose eyes or skin to direct UVC light from any source.

To prevent water damage or electric shock, do not mount unit under a humidifier.

Designed for a closed duct system. Do not mount near a supply or a return air opening.

This product is designed for installation in the interior of weather-protected HVAC equipment or ductwork, or on the exterior of protected ductwork only. For use on gas-fired, oil-fired, electric, split system, heat pump forced air systems*, and the interior of weather-protected heat pump packaged units**.

*Split system heat pumps are systems where the air handler and the air conditioning compressor are separate units.

**Packaged units are systems where the air handler and the air conditioning compressor are built together and are installed outside of the building.

1. Choose a suitable location for the lamp in the supply plenum, return plenum, or air handler, preferably downstream from the air filter. For optimum “cleaning” effect on the A coil, mount the unit above or below the A coil as close as possible while still illuminating the entire surface on the coil. (See Figure 1)
2. Clean the mounting surface with degreaser and let dry. The mounting surface must be clean and dry.
3. Attach the Shield to the Mounting Bracket Assembly, if it is to be used, by bending the tabs on the shield over the Lamp Bracket notches (see Figure 2). This will hold the shield in place during installation and lamp replacement. The shield will be held firmly in place when the lamp is installed.
4. Attach the Lamp to the Mounting Bracket Assembly with the supplied #8-32 wing nuts (see Dimensional Drawing). Remove tag and alcohol swab from the lamp, and clean the lamp glass with the alcohol swab. Avoid touching the cleaned lamp with your hands.
5. Separate the Lamp Cable from the Ballast output cable connector, if attached. The cables have watertight connectors to allow ease of installation and service (see Figure 3). Some newer ballasts do not require the separate lamp cable and have the lamp connector built in.

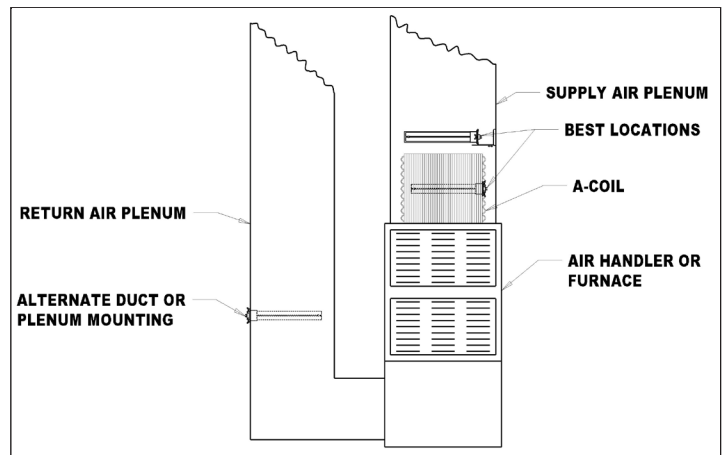

Figure 1 - Typical Installation



Figure 2



Figure 3



INTERNAL MOUNT INSTALLATION INSIDE PLENUM OR AIR HANDLER

- Attach the Lamp connector to the lamp base, ensuring correct alignment of the rectangular pin arrangement. The connector may be connected in either of two positions for which the pins line up. Ensure that the lamp connector is firmly attached and that the sealing boot is pushed fully onto the lamp base.
- Attach the Mounting Bracket Assembly to the mounting surface using the magnet. If the mounting surface is insulated, slit the insulation, insert the magnet through the slit, draw the insulation back over the magnet and bracket surface, and tape closed using metal tape or other means that would not be affected by UVC rays.
Some surfaces may be inadequate for mounting with the magnet (rough, uneven, heavy paint, etc.) The magnet may be removed from the Mounting Bracket Assembly, and the bracket assembly attached to the mounting surface with included self-drilling metal screws or other appropriate fasteners. Holes are provided on the bracket assembly for this purpose. Use care to avoid equipment damage to concealed wiring and other components when installing fasteners.
- If desired, loosen the wing nut on the bottom of the Mounting Bracket Assembly (see Dimensional Drawing), and swivel/extend the lamp bracket to position the lamp in the desired position, and re-tighten the wing nut securely.

CAUTION: Make certain that power has been disconnected to the HVAC system, and the 24 VAC transformer power source, before proceeding with the installation.

- Mount the 50VA, 24VAC transformer (not included) in an area protected from the lamp, using the included sheet metal screws or other appropriate fasteners, and connect to 120V power source. Observe all local and national electrical and mechanical code requirements regarding 120V wiring.

NOTE: It is recommended that the 120V ballast power source be wired through a safety disconnect switch, such as a door switch, that will disconnect power to the transformer if the access panel to the UVC lamp installation area is removed (see Wiring Diagram). If such a switch is not present on the equipment, it is recommended that a door interlock switch (not included, min. 3A 24VAC rating) be installed and wired into the 24VAC ballast power circuit (see Wiring Diagram).

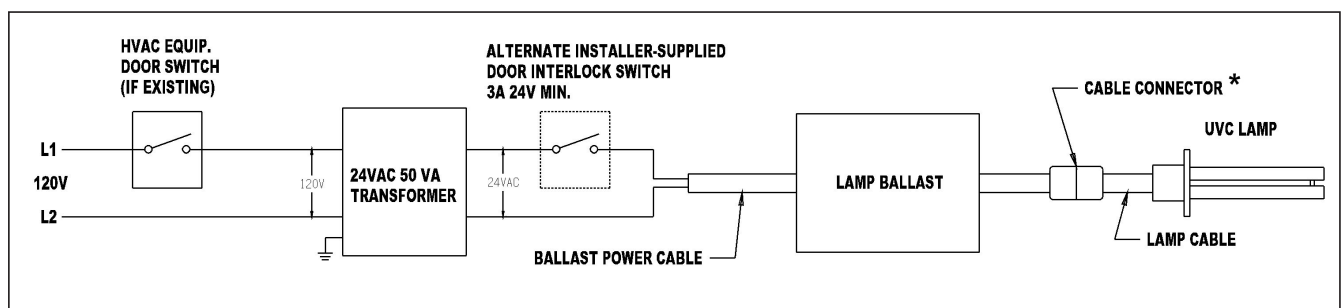

- Mount the ballast using the included sheet metal screws or other appropriate fasteners, in a location close enough to connect the 24VAC ballast power wires to the 24VAC transformer (not included), and to connect the ballast lamp cable to the lamp. If the ballast is not in a location protected from UVC exposure, protect the ballast with the included shield, or by fabricating and installing a sheet metal shield or equivalent. **DO NOT** wrap the ballast in tape or cover the ballast with anything that would insulate or reduce the ability of the ballast to dissipate heat.
- Route the Ballast output cable (watertight connector on the end) to mate with the Lamp Cable, and provide sufficient support to prevent entanglement with other components (such as a blower wheel or removable panel fasteners), and reduce stress on the Mounting Bracket Assembly. If ballast does not have the connector, skip to step 13.



INTERNAL MOUNT INSTALLATION INSIDE PLENUM OR AIR HANDLER

12. Connect the Lamp Cable connector to the matching connector on the Ballast output cable and ensure that the connectors are fully mated. These connectors are designed to prevent misalignment of the mating connectors; line up the projecting tabs of both connectors to allow connection (see Figure 3).
13. Connect the ballast 24VAC power cable to the 24 VAC transformer secondary (output) terminals (see Wiring Diagram), or the alternate installer-supplied door interlock switch if used. Secure the cable to prevent entanglement with other components (such as a blower wheel or removable panel fasteners).
14. Identify an area of the access panel or other area of the equipment or duct through which the lamp may be seen. Verify that the surface is free of dirt, oil, and other contaminants, peel off the label and apply the Safety label to the surface such that the warning information is clearly visible *see Figure 8).
15. Drill a 3/8" hole through the center of the Safety Label, where indicated by the dashed circle (see Figure 7).
16. Snap the clear plastic Safety Viewport into the hole (see Figure 8). The lamp may be safely viewed through the viewport while it is lit.
17. Verify that all electrical connections are tight and that the lamp and bracket is secure.
18. Replace all access panels and other items that may have been removed during the installation, such as electrical box covers, etc.
19. Verify that the Safety Viewport is securely fastened in the hole drilled through the safety Label.

WARNING: Before restoring power to the HVAC system or the transformer power source, verify that no openings exist through which UVC rays from the lamp may escape. Verify that all access panels and ductwork etc. have been replaced and sealed if necessary, and that the safety viewport is securely fastened in place.

20. Restore power to the HVAC system and the transformer power source. Look through the Safety Viewport to verify that the lamp is lit.



BRACKET MOUNT INSTALLATION THROUGH A-COIL DELTA PLATE OR PLENUM

If the lamp is to be mounted externally on the plenum or an air duct, or if the lamp is to be mounted through a delta plate (covers the end of the A-coil in certain air handler designs), follow these steps for installation:

1. Separate the lamp mounting portion of the lamp bracket from the remainder of the lamp bracket (see Figure 4), by bending back and forth or cut with snips or hacksaw.
2. Attach the shield to the separated bracket, on the side opposite from the lamp mounting studs (see Figure 5), if it is to be used, using the supplied #8-32 self-threading screws.
3. Insert the lamp through the oval hole in the bracket and shield base, and attach to the mounting studs using the supplied #8-32 locking nuts (see Figure 5). Do not use the supplied #8-32 wingnuts, unless the lamp is to be installed inside an air Figure 5 handler or other equipment or structure requiring the use of a tool to access.

WARNING: DO NOT use the supplied wingnut if the lamp bracket is installed externally on a duct or surface not internal to an air handler or duct system! For safety, a hand tool is required to remove the lamp if the installation is not internal as described.

4. Mark the location for the lamp, and drill or cut a 2" round hole (may be an oval hole 2" x 1" if the shield is not used) in the mounting surface, using care to avoid damage to equipment or concealed wiring. If the lamp is to be mounted on duct board, fabricate a mounting surface by cutting a 6" x 6" square of suitable sheet metal. Cut the hole for the lamp in the sheet metal and the duct board, and tape the sheet metal securely to the duct board using mastic-backed metal tape.
5. Insert the lamp through the hole, orient the lamp such that it presents the least obstruction to airflow or that the shield is in proper position, and secure the bracket to the mounting surface using three of the supplied sheet-metal screws, or other appropriate fasteners.
6. If mounting through the exterior of a plenum or air duct, use metal duct sealing tape (not included) to tape around the edges of the mounting bracket, to prevent UVC rays from escaping and prevent duct leakage.
7. Position the supplied cable on the lamp cable such that the clamp hole is aligned with the fourth hole in the bracket, and loosely install the fourth screw or fastener through the clamp and bracket, into the mounting surface (see Figure 6).

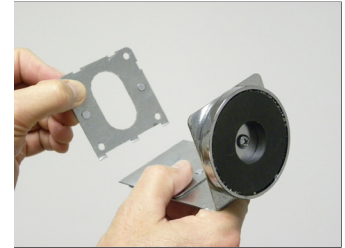

Figure 4

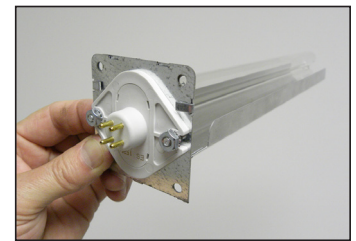

Figure 5



Figure 6



BRACKET MOUNT INSTALLATION THROUGH A-COIL DELTA PLATE OR PLENUM

8. Follow steps 9-20 in the Magnet Mount Installation section to complete the installation (see Figures 7, 8, 9).

WARNING: Ensure that the cable clamp prevents removal of the lamp from the bracket unless the lamp cable is disconnected from the lamp! This step is important to prevent the inadvertent removal of the lamp from the bracket before disconnecting the lamp cable from the lamp.

CAUTION: Make certain that power has been disconnected to the HVAC system, and the 24VAC transformer power source, before proceeding with the installation!

WARNING: Before restoring power to the HVAC system or the transformer power source, verify that no openings exist through which UVC rays from the lamp may escape. Verify that all access panels and ductwork etc. have been replaced and sealed if necessary, and that the safety viewport is securely fastened in place.



Figure 7



Figure 8



Figure 9



MAINTENANCE

1. Inspect and clean lamp at least every 6 months.
2. Replace your lamp once a year to maintain the lamps maximum output intensity. The lamp should operate continuously for maximum lamp life and light effectiveness.

LAMP REPLACEMENT PROCEDURE

WARNING: Disconnect 120V power to the 24VAC transformer before proceeding with lamp replacement or other maintenance. If the lamp is mounted externally on a plenum or air duct, disconnect the lamp cable from the lamp before removing the lamp from the external mount bracket. Verify that the lamp is not lit by looking through the safety viewport before removing any access panels, or the amp from the external mount bracket.

1. Verify that the lamp is not lit by looking through the safety viewport.
2. Disconnect the Lamp Cable connector from end of lamp
3. Loosen the swivel clamp nut holding the lamp on the mounting bracket and remove the lamp, using care to avoid breaking the lamp.

Note: When replacing the lamp, always wipe off lamp before installing.

4. Install the replacement lamp onto the mounting bracket and tighten swivel clamp nut.

Note: UV lamps contain a small amount of mercury, like a typical fluorescent lamp. Check with your local waste management authority for local disposal or recycling requirements. According to the EPA's Universal Waste Rule, these types of lamps may be disposed of into household waste.

5. Attach the Lamp Cable connector to the lamp.
6. After replacing lamp, make sure a new UV Hazard Warning Label (supplied with lamp replacement) is applied to the HVAC equipment or duct and dated with the date of installation.
7. Restore power to the HVAC system and the transformer power source. Look through the Safety Viewport to verify that the lamp is lit.

TROUBLESHOOTING

1. If the lamp does not light up:
 - A. Check the lamp for burned-out filaments at either end. Discoloration due to heat is normal.
 - B. Check for 24V from the transformer to the ballast.
 - C. Check the lamp cable connection to the lamp.
2. If the lamp still does not light, replace the lamp.
3. If the lamp still does not light up after replacing the lamp, replace ballast.



APPENDIX A: SIZING INFORMATION FOR COIL IRRADIATION APPLICATIONS

NUMBER OF UV-17FM UNITS FOR COIL IRRADIATION *

| | | COIL WIDTH | | | | | | | | | | |
|-------------|----|-------------|-------------|-------------|-------------|-------------|-------------|-------------|-------------|-------------|-------------|-------------|
| | | 22 | 24 | 28 | 30 | 34 | 40 | 48 | 58 | 62 | 66 | 68 |
| COIL HEIGHT | 20 | (1) UV-17FM | (1) UV-17FM | (1) UV-17FM | (1) UV-17FM | | | | | | | |
| | 24 | (1) UV-17FM | (1) UV-17FM | (1) UV-17FM | (1) UV-17FM | (2) UV-17FM | (2) UV-17FM | | | | | |
| | 30 | (1) UV-17FM | (1) UV-17FM | (1) UV-17FM | (1) UV-17FM | (2) UV-17FM | (2) UV-17FM | (2) UV-17FM | | | | |
| | 32 | | (1) UV-17FM | (1) UV-17FM | (1) UV-17FM | (2) UV-17FM | (2) UV-17FM | (2) UV-17FM | (2) UV-17FM | (2) UV-17FM | (2) UV-17FM | |
| | 34 | | (1) UV-17FM | (1) UV-17FM | (1) UV-17FM | (2) UV-17FM | (2) UV-17FM | (2) UV-17FM | (2) UV-17FM | (2) UV-17FM | (2) UV-17FM | |
| | 38 | | (1) UV-17FM | (1) UV-17FM | (2) UV-17FM | (2) UV-17FM | (4) UV-17FM | (4) UV-17FM | (4) UV-17FM | (4) UV-17FM | (4) UV-17FM | (6) UV-17FM |
| | 40 | | | (1) UV-17FM | (2) UV-17FM | (2) UV-17FM | (4) UV-17FM | (4) UV-17FM | (4) UV-17FM | (4) UV-17FM | (4) UV-17FM | (6) UV-17FM |
| | 48 | | | | (2) UV-17FM | (2) UV-17FM | (4) UV-17FM | (4) UV-17FM | (4) UV-17FM | (6) UV-17FM | (6) UV-17FM | (6) UV-17FM |

- *NOTE: These are minimum recommendations for effective coil irradiation, when installed as follows:
- Lamp should be installed with reflectors directing reflected rays towards the coil.
 - Lamps should be placed 12" away from coil if possible.
 - Horizontal lamp placement is preferred for optimal coil irradiation effectiveness.

APPENDIX B: SIZING INFORMATION FOR AIR DISINFECTION APPLICATIONS

MINIMUM RECOMMENDED NUMBER OF UV-17FM UNITS FOR DISINFECTION *

| | | COIL WIDTH | | | | | | | | | | |
|-----------------------|----|-------------|-------------|-------------|-------------|-------------|--------------|--------------|--------------|--------------|--------------|--------------|
| | | 22 | 24 | 28 | 30 | 34 | 40 | 48 | 58 | 62 | 66 | 68 |
| DUCT OR PLENUM HEIGHT | 20 | (2) UV-17FM | (3) UV-17FM | (3) UV-17FM | (3) UV-17FM | | | | | | | |
| | 24 | (3) UV-17FM | (3) UV-17FM | (3) UV-17FM | (4) UV-17FM | (4) UV-17FM | (6) UV-17FM | | | | | |
| | 30 | (3) UV-17FM | (3) UV-17FM | (4) UV-17FM | (6) UV-17FM | (6) UV-17FM | (6) UV-17FM | (6) UV-17FM | | | | |
| | 32 | | (3) UV-17FM | (4) UV-17FM | (6) UV-17FM | (6) UV-17FM | (6) UV-17FM | (8) UV-17FM | (10) UV-17FM | (10) UV-17FM | (10) UV-17FM | |
| | 34 | | (4) UV-17FM | (6) UV-17FM | (6) UV-17FM | (6) UV-17FM | (8) UV-17FM | (8) UV-17FM | (10) UV-17FM | (10) UV-17FM | (12) UV-17FM | |
| | 38 | | (4) UV-17FM | (6) UV-17FM | (6) UV-17FM | (6) UV-17FM | (8) UV-17FM | (10) UV-17FM | (10) UV-17FM | (12) UV-17FM | (12) UV-17FM | (12) UV-17FM |
| | 40 | | | (6) UV-17FM | (6) UV-17FM | (8) UV-17FM | (8) UV-17FM | (10) UV-17FM | (12) UV-17FM | (12) UV-17FM | (12) UV-17FM | (14) UV-17FM |
| | 48 | | | | (8) UV-17FM | (8) UV-17FM | (10) UV-17FM | (12) UV-17FM | (14) UV-17FM | (14) UV-17FM | (16) UV-17FM | (16) UV-17FM |

- *NOTE: These recommendations are given for pathogens having UVC deactivation rate constant of approximately $4\text{cm}^2/\text{mJ}$ or greater, and are based on an array of lamps mounted in a plane perpendicular to the direction of air flow in a rectangular duct or plenum, and in accordance with the minimum and maximum dimensions as shown in the diagram. In the diagram, the duct wall is a cross-section of the duct or plenum, with the airflow direction either into or out of the illustration.

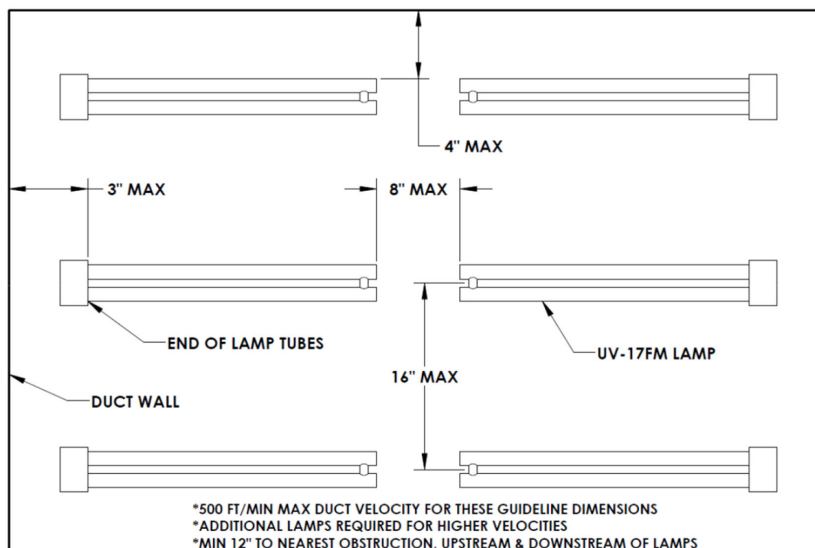

THIS PAGE INTENTIONALLY LEFT BLANK

This manual may be downloaded and printed from the Field Controls website (www.fieldcontrols.com)

WARRANTY

For warranty information about this or any Field Controls product, visit:
www.fieldcontrols.com/ventCool

Field Controls Technical Support
1.800.742.8368
fieldtec@fieldcontrols.com



FIELDCONTROLS

Phone: 252.522.3031 • Fax: 252.522.0214
www.fieldcontrols.com