

ENGINEERING DATA



UV-AIRE™ UVX IN-DUCT AIR PURIFIER

Models: UVX-16/24, UVX-16/120, & UVMAX



MODEL

| | |
|-----------|-----------|
| UVX-16/24 | 602616241 |
| UVX-16/20 | 602616121 |
| UVMAX | 602620520 |

INCLUDED IN KIT

- Power Supply
- UVC Lamp
- 10' Pig-Tail Power Cord (24V ONLY)
- 10' 3-Prong Power Cord (120V & UVMAX)
- Mounting Hardware (10)
- View Port
- Installation Manual

REPLACEMENT PARTS

| | |
|-------------------|-----------|
| 16" 24V UVC Lamp | 602617024 |
| 16" 120V UVC Lamp | 602617120 |

CERTIFICATIONS

Safety cULus

SHIPPING DIMENSIONS

| | |
|--------|---------------------------|
| Carton | 22 5/8" x 5 1/2" x 4 1/8" |
| Weight | 6 lbs. (UV-16/24) |
| | 5 lbs. (UV-16/120) |
| | 6 lbs (UVMAX) |



Field Controls
2630 Airport Road
Kinston, NC 28504

252 522-3031
Fax: 1 (800) 367-7942

Visit us at: www.fieldcontrols.com

DESCRIPTION

The most powerful residential UV-C light product for HVAC systems in the industry. Simple and easy install and service. Trusted reliability and support. Actively clean the air system clean and improve indoor air quality.

FEATURES/BENEFITS

| | |
|------------------------------|---|
| High Output UVC | Highest UVC (254nm) output of any residential in-duct UV product on the market. |
| 2-year UVC 254nm quartz lamp | Long-lasting, safe, and effective lamps. |
| Ozone-free Operation | Third party tested, ensures no harmful by-products are introduced to the air. |
| Active Cleaning | Reduces viruses, bacteria, fungi*, and odors |
| Easy and Simple Maintenance | Quick Turn-Lock™ design allows for easy lamp replacement |
| Warranty | 10-year warranty, 90 day lamp warranty |

*Demonstrated >99% reduction of virus MS-2 bacteriophage in <10 minutes, >99% reduction of bacterium Staphylococcus aureus in <5 minutes, and >80% reduction of fungi Aspergillus Niger in 60 minutes.

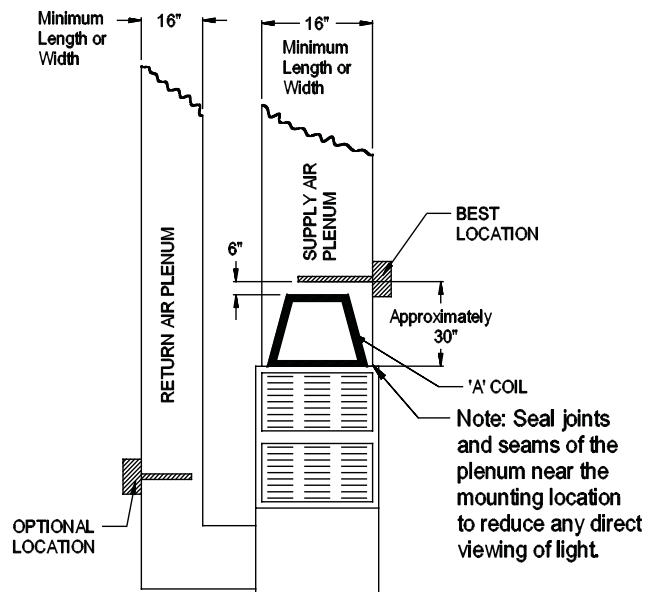

Field Controls LLC reserves the right to modify a product, without prior notice, whether in design, color or specifications, in order to offer at all times a quality product that is highly competitive. Please consult your national and local building codes to find out whether the installation of electrical products requires the services of a certified technician or electrician. Field Controls and UV-AIRE™ are registered Trademarks used under license by Field Controls LLC. All rights reserved.

ENGINEERING DATA

PRODUCT SPECIFICATIONS

| | UVX-16/24 | UVX-16/120 | UVMAX |
|--|---|--|--|
| UV LAMP | 254 nm UVC, 62 mW/cm ² @ 1 Meter 425mA, 21W Quartz Ceramic | 254 nm UVC, 132 mW/cm ² @ 1 Meter 800mA, 36W Quartz Ceramic | 254 nm UVC, 132 mW/cm ² @ 1 Meter (per lamp) 800mA, 36W (per lamp) Quartz Ceramic |
| ELECTRICAL | 24V, 50/60Hz, 2.6A, 70W | 100-230 VAC, 50/60Hz, 1.2A, 140-324W | 100-230 VAC, 50/60Hz, 1.2A, 140-324W |
| SIZING | Up to 2000 Sq. ft. | Up to 2000 Sq. ft. | Between 2000 to 4000 Sq. Ft |
| INCOMING POWER CABLE | 10 Ft. NEMA 5-15P to C13 Plug | 10 Ft. Pigtail to C13 Plug | 10 Ft. Pigtail to C13 Plug |
| LAMP CABLE | 4 Ft. | | |
| TEMPERATURE RANGE | -22 to 140° Ambient Indoor Temperatures | | |
| BALLAST & POWER HEAD MOUNTING | 0.170" Hole Diameter, #8 Type AB Screws (Included) | | |

DIMENSIONAL DATA

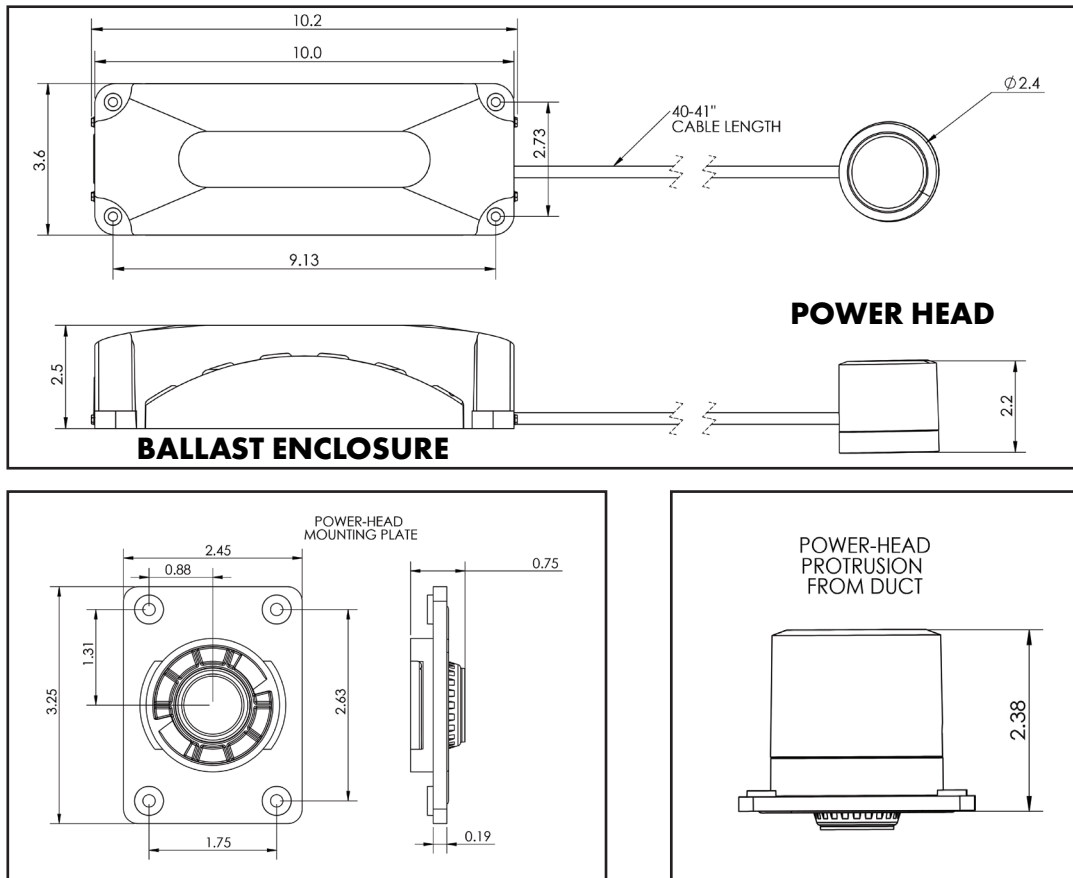

PROJECT INFORMATION

| | |
|--------------------|-----------------|
| Quoted by: | Date: |
| Project: | Remarks: |
| Quantity: | |
| Model: | |
| Site: | |
| Architect: | |
| Engineer: | |
| Contractor: | |



Field Controls
2630 Airport Road
Kinston, NC 28504
252 522-3031
Fax: 1 (800) 367-7942

Visit us at: www.fieldcontrols.com