



INSTALLATION MANUAL



This symbol on the product means the Commercial UV is listed by Underwriters Laboratories, Inc



COMMERCIAL UV AIR PURIFYING SYSTEM

Models: CUV-1118DN, CUV-1123SN, CUV-1123DN, CUV-1123SC, 1123DC, 1128SN, 1128DN, 1128SC, 1128DC, 1134SN, 1134DN, 1134SC, 1134DC, 1538SN, 1538DN, 1538SC, 1538DC, 1546SN, 1546SC, 1546DC, 1558SN, 1558DN, 1558SC, & 1558DC

READ THESE INSTRUCTIONS CAREFULLY AND COMPLETELY BEFORE PROCEEDING WITH THE INSTALLATION

This device MUST be installed by a qualified agency in accordance with the manufacturer's installation instructions. The definition of a qualified agency is: any individual, firm, corporation or company which either in person or through a representative is engaged in, and is responsible for, the installation and operation of HVAC appliances, who is experienced in such work, familiar with all the precautions required, and has complied with all the requirements of the authority having jurisdiction. Please retain these instructions after installation.

THIS PAGE INTENTIONALLY LEFT BLANK

The Air Purifying System you have purchased has been designed to be simple to install, operate and maintain. Read this manual before you install the air purifying system.

This product should be installed according to local and national codes and standards.



Parts included in Air Purifier System package:



1. Magnetic Mount Power Enclosure
2. Lamp Support Rod(s)
3. UVC Lamp(s)
4. Access Panel Warning Label
5. Tie Wraps
6. Lamp Install Label
7. Lamp Cleaning Kit
8. Installation Manual

Replacement Parts:



1. See page 21

TABLE OF CONTENTS

Product Overview.....5
Safety Consideration.....5 - 7
Installation & Operation.....7 - 8
UV Lamps & Cable Connection.....9
Generic Product Kit.....10
Wiring.....11 - 12
Mounting13 - 18
Optional Status Display Module.....19
Maintenance.....20
Troubleshooting Guide.....20
Replacement & Spare Parts List.....21

PRODUCT OVERVIEW

The UV-Aire unit is designed to emit High Output UVC Wavelength light rays which inactivate and sterilize airborne microorganisms as they pass through a HVAC system or ductwork. The UV-Aire Purifying System models have been designed for use as coil irradiation and/or for air disinfection.

This product is not sold as a medical device and is not for the purpose of diagnosis of any disease or condition, nor for use in the mitigation, treatment or prevention of any disease or condition.

The aspects associated with the use of this product and its ability to aid in disinfection of environmental air have not been investigated by UL.

SAFETY CONSIDERATIONS

Understand the signal words DANGER, WARNING, and CAUTION. These words are universally used for overall safety. DANGER identifies the most serious hazards which will result in severe personal injury or death. WARNING signifies hazards which could result in personal injury or death. CAUTION is used to identify unsafe practices resulting in minor personal injury or product and property damage.

DANGER: Before performing maintenance or service on system, ensure power is de-energized prior to service. Electrical shock can cause injury or death.

WARNING: UV light will break down plastic materials not rated for UV exposure.

- The unit must be mounted at least 20" from the above stated type of materials.
- If it is necessary to mount the unit in direct line of site of these types of materials, they must be shielded with aluminum foil, metal foil tape or sheet metal.

WARNING: Before installing or servicing UV-Aire system, always turn all power OFF and have unit unplugged. Electrical shock can cause personal injury or death. Never expose eyes or skin to direct UVC light from any source.

WARNING: The electrical supply circuit connected to this UV appliance shall be routed through an electrical interlock switch placed on the HVAC system duct access panels and doors to prevent accidental UV exposure when servicing the air ducts or equipment. Interlock shall break all supply conductors.

WARNING: DO NOT mount the UV Lamps outdoors. The magnetic mount power enclosure is designed to be mounted indoor or with accessory mounting kit for outdoor locations.

WARNING: Never touch broken UV lamp or internal contents of UV lamp. The lamp contains mercury.

- In case of accidental exposure to internal contents of lamp, wash hands and any other affected skin area with mild detergent. Remove affected clothing immediately. If skin surface is pierced, seek medical attention immediately.
- If UV lamp breaks, clean and dispose of with the same care as a fluorescent lamp.
- UV lamps must be disposed of in accordance with local, state and federal environmental disposal laws.

CAUTION: Equipment damage hazard. Ultraviolet light can cause color shift or surface degradation and sometimes structural degradation of non-metallic components. Select mounting location that prevents exposure to plastic flexible duct components, polyurethane foam insulation material, rubber hoses, wire insulation, etc. If mounting options are limited, items above should be protected with ultraviolet resistant material such as aluminum foil, aluminum duct tape, or metallic shields or metallic tapes.

CAUTION: If you touch the glass of the lamp, you should wipe the glass clean with isopropyl alcohol and a lint free wipe. If the lamp is not cleaned, the oil film left on the glass lamp surface from your hand causes a reduction in the light intensity.



CAUTION: Never expose eyes or skin to UVC light from any source.

- Looking directly at the UVC light may cause permanent eye damage or blindness.
- Never operate the UV-Aire Air Purifying System out of the plenum.
- Designed for a closed duct system. Do not mount near a supply or a return air opening.
- All duct openings in direct line of site of the UV light must be sealed with aluminum tape or equivalent sealing methods.

CAUTION: UV Lamps are fragile. To prevent accidental breakage, handle UV lamp with care.

CAUTION: Resistance to UV radiation: Polymeric cabinet, structural, and current carrying parts and wiring which are subjected to UV-C irradiation from a UV lamp system shall be shielded from or out of the line-of-sight of the UVC light, or be constructed of a material that is capable of withstanding UVC exposure levels expected in the product without degrading.

CONSIDÉRATIONS DE SÉCURITÉ

Comprenez les mots indicateurs DANGER, AVERTISSEMENT et PRUDENCE. Ces mots sont universellement utilisés pour la sécurité globale. DANGER identifie les dangers les plus graves qui entraîneront des blessures corporelles graves ou la mort. AVERTISSEMENT signifie les dangers qui pourraient entraîner des blessures corporelles ou la mort. LA PRUDENCE est utilisée pour identifier les pratiques dangereuses entraînant des blessures corporelles mineures ou des dommages aux produits et aux biens.

DANGER: Avant d'effectuer la maintenance ou l'entretien du système, assurez-vous que l'alimentation est coupée sous tension avant l'entretien. Les chocs électriques peuvent causer des blessures ou la mort.

AVERTISSEMENT: La lumière UV décomposera les matières plastiques non conçues pour l'exposition aux UV.

- L'unité doit être montée à au moins 20 » à partir du type de matériaux indiqué ci-dessus.
- S'il est nécessaire de monter l'unité en ligne directe de site de ces types de matériaux, ils doivent être blindés avec du papier d'aluminium, du ruban de feuille de métal ou de la tôle.

AVERTISSEMENT: Avant d'installer ou d'entretenir le système UV-Aire, éteignez toujours toute la mise hors tension et débranchez l'appareil. Les chocs électriques peuvent causer des blessures corporelles ou la mort. N'exposez jamais les yeux ou la peau à la lumière UVC directe de quelque source que ce soit.

AVERTISSEMENT: Le circuit d'alimentation électrique connecté à cet appareil UV doit être acheminé par un interrupteur de verrouillage électrique placé sur les panneaux d'accès et les portes des conduits du système CVC afin d'éviter toute exposition accidentelle aux UV lors de l'entretien des conduits d'air ou de l'équipement. Le verrouillage doit briser tous les conducteurs d'alimentation.

AVERTISSEMENT: NE MONTEZ PAS les lampes UV à l'extérieur. Le boîtier d'alimentation à montage magnétique est conçu pour être monté à l'intérieur ou avec un kit de montage d'accessoires pour les emplacements extérieurs.

AVERTISSEMENT: Ne touchez jamais la lampe UV cassée ou le contenu interne de la lampe UV. La lampe contient du mercure.

- En cas d'exposition accidentelle au contenu interne de la lampe, lavez-vous les mains et toute autre zone de la peau affectée avec un détergent doux. Retirez immédiatement les vêtements touchés. Si la surface de la peau est percée, consultez immédiatement un médecin.
- Si la lampe UV se casse, nettoyez et jetez-la avec le même soin qu'une lampe fluorescente. sur l'élimination de l'environnement.

LA PRUDENCE: Risque d'endommagement de l'équipement. La lumière ultraviolette peut provoquer un changement de couleur ou une dégradation de la surface et parfois une dégradation structurelle de composants non métalliques. Choisissez l'emplacement de montage qui empêche l'exposition aux composants de conduits flexibles en plastique, au matériau isolant en mousse de polyuréthane, aux tuyaux en caoutchouc, à l'isolation des fils, etc. Si les options de montage sont limitées, les éléments ci-dessus doivent être protégés avec un matériau résistant aux ultraviolets tel qu'une feuille d'aluminium, du ruban adhésif en aluminium, des boucliers métalliques ou des rubans métalliques.

LA PRUDENCE: Si vous touchez le verre de la lampe, vous devez essuyer le verre avec de l'alcool isopropylique et une lingette non pelucheuse. Si la lampe n'est pas nettoyée, le film d'huile laissé sur la surface de la lampe en verre de votre main provoque une réduction de l'intensité lumineuse.



SAFETY CONSIDERATIONS - CONTINUED

LA PRUDENCE: N'exposez jamais les yeux ou la peau à la lumière UVC provenant de quelque source que ce soit.

- Regarder directement la lumière UVC peut causer des lésions oculaires permanentes ou la cécité.
- Ne faites jamais fonctionner le système de purification de l'air UV-Aire hors du plénum.
- Conçu pour un système de conduits fermés. Ne pas monter près d'une ouverture d'alimentation ou d'air de retour.
- Toutes les ouvertures de conduits en ligne directe du site de la lumière UV doivent être scellées avec du ruban d'aluminium ou des méthodes d'étanchéité équivalentes.

LA PRUDENCE: Les lampes UV sont fragiles. Pour éviter toute casse accidentelle, manipulez la lampe UV avec soin.

LA PRUDENCE: Résistance au rayonnement UV: Les pièces et le câblage en polymère de l'armoire, de la structure et du courant qui sont soumis à l'irradiance UC-C d'un système de lampe UV doivent être protégés ou hors de la ligne de mire de la lumière UVC, ou être construits dans un matériau capable de résister aux naevus d'exposition aux UVC attendus dans le produit sans se dégrader avec du ruban d'aluminium ou des méthodes d'étanchéité équivalentes.

LA PRUDENCE: Les lampes UV sont fragiles. Pour éviter toute casse accidentelle, manipulez la lampe UV avec soin.

LA PRUDENCE: Résistance au rayonnement UV: Les pièces et le câblage en polymère de l'armoire, de la structure et du courant qui sont soumis à l'irradiance UC-C d'un système de lampe UV doivent être protégés ou hors de la ligne de mire de la lumière UVC, ou être construits dans un matériau capable de résister aux naevus d'exposition aux UVC attendus dans le produit sans se dégrader

INSTALLATION & OPERATION

The UV-Aire models consists of 4 main components: Magnetic Mount Power Enclosure, Lamp Support Rod(s), Ultraviolet Lamp(s), and generic product kit.

MAGNET MOUNT POWER ENCLOSURE

The Magnetic Mount Power Enclosure is designed to directly mount to any steel metal surface. This enclosure is equipped with flanged end plates for mechanical screw fasteners, if desired. There is no reason to remove the magnet mounts if using the alternative mechanical screw fastener method. The power enclosure housing the UV lamp ballast power supply in a sealed, aluminum extruded housing with gasketed ring sealed screw on end plates to form dust and water tight enclosure. The magnetic mount power enclosure is shipped with the following cables prewired and protruding from its end plates via water tight strain relief connectors:

1. One or Two UV lamp cables depending on Single or Dual Lamp model installed,
2. Main Power Cable, SO Type Cable, roughly 115" in length

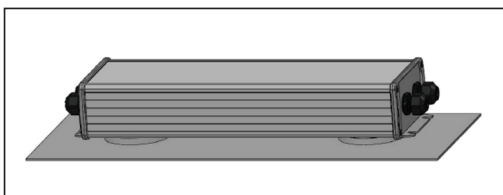

Figure 1A

Using Magnet to Mount Power Enclosure

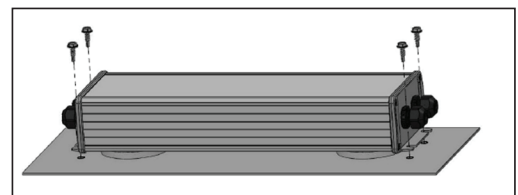

Figure 1B

Alternative Magnetic Mount Power Screw Mounting



INSTALLATION & OPERATION - CONTINUED

When installing the Magnetic Mount Power Enclosure, adhere to the following instructions:

- Mount the power enclosure directly to a metal surface
- Use alternative screw mounting method, if not directly mounted to a metal surface and/or has excessive vibration or mounting surface is not horizontal.
- Route power cable and UV lamp cable(s) in a manner to shield or limit exposure to ultraviolet ray. If cables are in direct exposure to lamp ultraviolet rays, then cover/wrap cables with foil tape.
- Use the extra tie wraps to secure the cables in place as needed
- Secure the main power cable in place using a strain relief device/connector rated for the application as method of support at the electrical panel. The strain relief connector is supplied by the installer

LAMP SUPPORT ROD

The Lamp Support Rod is supplied with magnetic foot mounts. The lamp support rod are available in several variations: (Reference Figures 13 through 20)

1. Single Lamp Support - meaning one rod can support on UV lamp (Standard CUV Version)
2. Dual Lamp Support - meaning one rod can support two UV lamps (Standard DUV Version)
3. Lamp Support Kits Only - may contain mounting L brackets, lamp support brackets and magnetic disks with assembly hardware all shipped loose. Refer to optional lamp and 1/2" EMT conduit mounting accessories sections for additional information. The installer is responsible to supply the 1/2" EMT conduit, assemble and attach the mounting brackets and lamp support brackets to the EMT conduit (reference Figures 13, 14, 15, 16, 17, 18, 19 and 20) during installation.

CAUTION: Verify all fastener hardware is tight during installation.

LA PRUDENCE: Vérifiez que tout le matériel de fixation est étanche lors de l'installation.

The Lamp Support Rod is designed to directly mount to any steel metal surface. The L bracket design incorporates several additional mounting holes for alternative mechanical screw fastener mounting method. It is recommended to add alternative screw fasteners to lamp rod L-bracket when lamp rod L-bracket is not mounted on a horizontal surface. The alternative screw fasteners are to be provided by the installer. Refer to Figure 2 for Lamp Support Rod mounting details. If necessary, the magnets may be removed on lamp rod L-brackets but alternative mechanical screw fasteners must be installed to secure lamp brackets to mounting surface.

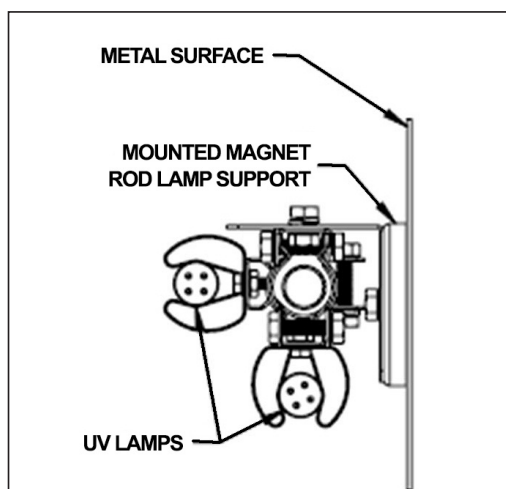

Figure 2A
Lamp Support Rod Standard Mounting
(Magnetic Mount)

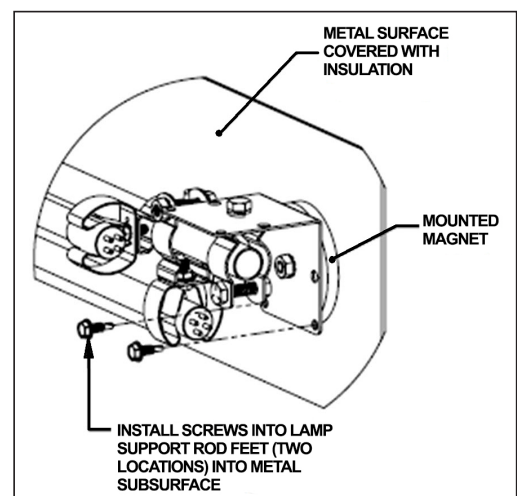

Figure 2B
Alternative Lamp Support Rod Mounting Method
using screws (Screw Mount)



UV LAMPS AND CABLE CONNECTION

The Ultraviolet lamps are germicidal type with 254nm wavelength. The Commercial UV Air Purifying System series offers two types of lamps in each length - non coated and coated. The coated lamps have a fluoropolymer film coating to assist glass and mercury containment should the lamp get broken. This fluoropolymer film coating reduces the overall lamp intensity output by a few percentage. Coated and non coated UV lamps are interchangeable with in the UV series product offering. The coated UV lamps are more expensive than the non coated UV lamps. Coated lamps have approximately 5% less output than non coated lamps.

WARNING: UV lamps must be disposed of in accordance with local, state and federal environmental laws.

AVERTISSEMENT: Les lampes UV doivent être éliminées conformément aux lois locales, étatiques et fédérales sur l'élimination de l'environnement.

UV lamps should be installed on Lamp Support Rod Assemblies with plastic/ceramic portion of the UV lamp sandwiched between the Inverted U-Shaped lamp supports. Refer to Figures 3A and 3B for correct and incorrect lamp mounting information.

The DUV and CUV models differ in length of UV cable provided. The DUV model comes standard with 40-inch long UV cable(s) and CUV model comes standard with 156-inch long UV cable(s).

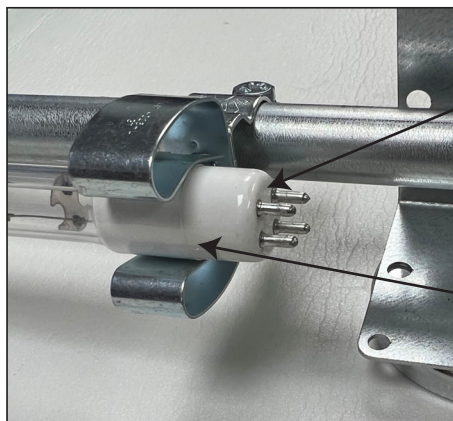

Figure 3A
Correct Lamp Support

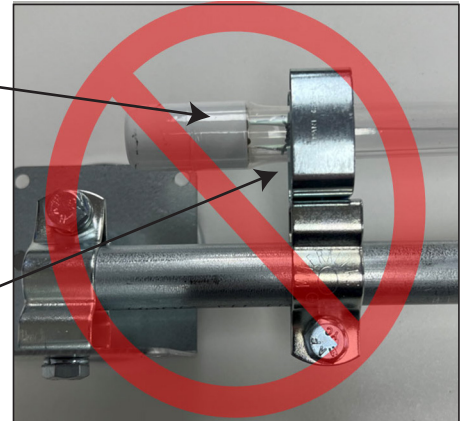

Figure 3B
Incorrect Lamp Support

The UV lamp cable is prewired from the magnetic power enclosure. The lamp connection side of the cable is shown in Figure 4A. The cable connector is keyed to match the UV lamp pins. Align the lamp pins with the connector and push together. If connection is not made easily, rotate the connector 90° and then push together. The proper lamp connection should match Figure 4B.

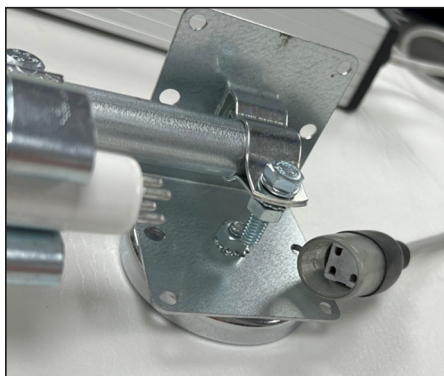

Figure 4A: UV Lamp Cable Connector and Lamp Pins
780108800 | RevC | 4/26

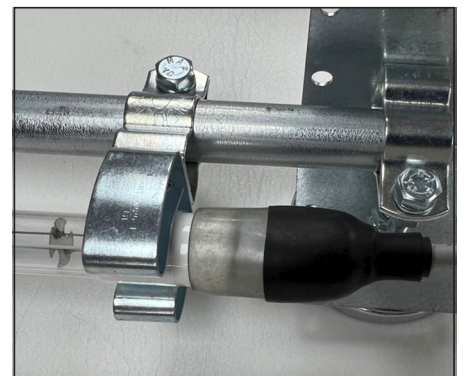

Figure 4B: Proper Cable and Lamp Connection



GENERIC PRODUCT KIT

The Generic Product Kit contains the instruction manual, tie wraps, access panel, UV lamp installation label and lamp cleaning kit.

Use the lamp cleaning kit which consists of an alcohol pad to wipe down the UV lamp, if you touch lamp glass surface with your hand or body. The oils from your hand or body can cause premature lamp failure if not cleaned off of lamp surface.

Install the Access Panel Label Warning to the outside surface of the removable access panel of the appliance. This should be the same access panel where the Electrical Interlock Switch assembly is installed to deactivate/power down UV product when panel is removed.

Fill in installation date or in service date for the UV lamps on the UV Lamp Installation Label using permanent marker and affix label some place near the UV lamps access panel as a reminder to replace the lamps every two (2) years.

The additional tie wraps are used to:

1. Secure Power Enclosure incoming power cable (SO Type Cable) to electrical panel connection.
2. Secure UV Lamp Cables

Refer to Diagram 1 for General Wiring Diagram for xUC-11xx model products and Diagram 2 for xUV-15xx model products.

CONTROL
WIRING
SOLUTIONS





WIRING

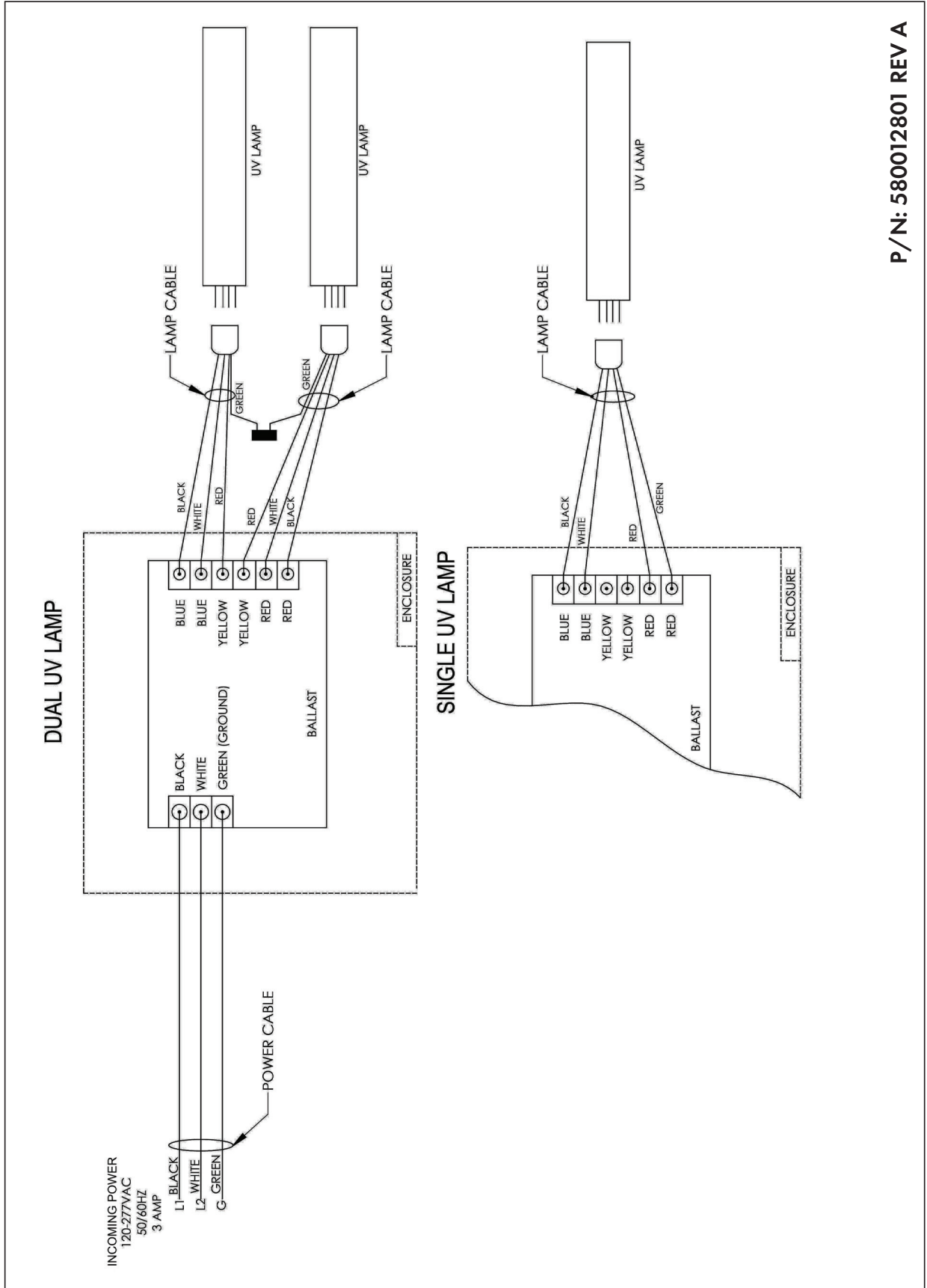

P/N: 580012801 REV A

Diagram 1: Electrical Wiring Schematic for xUV-11 xxxx Model Product



WIRING

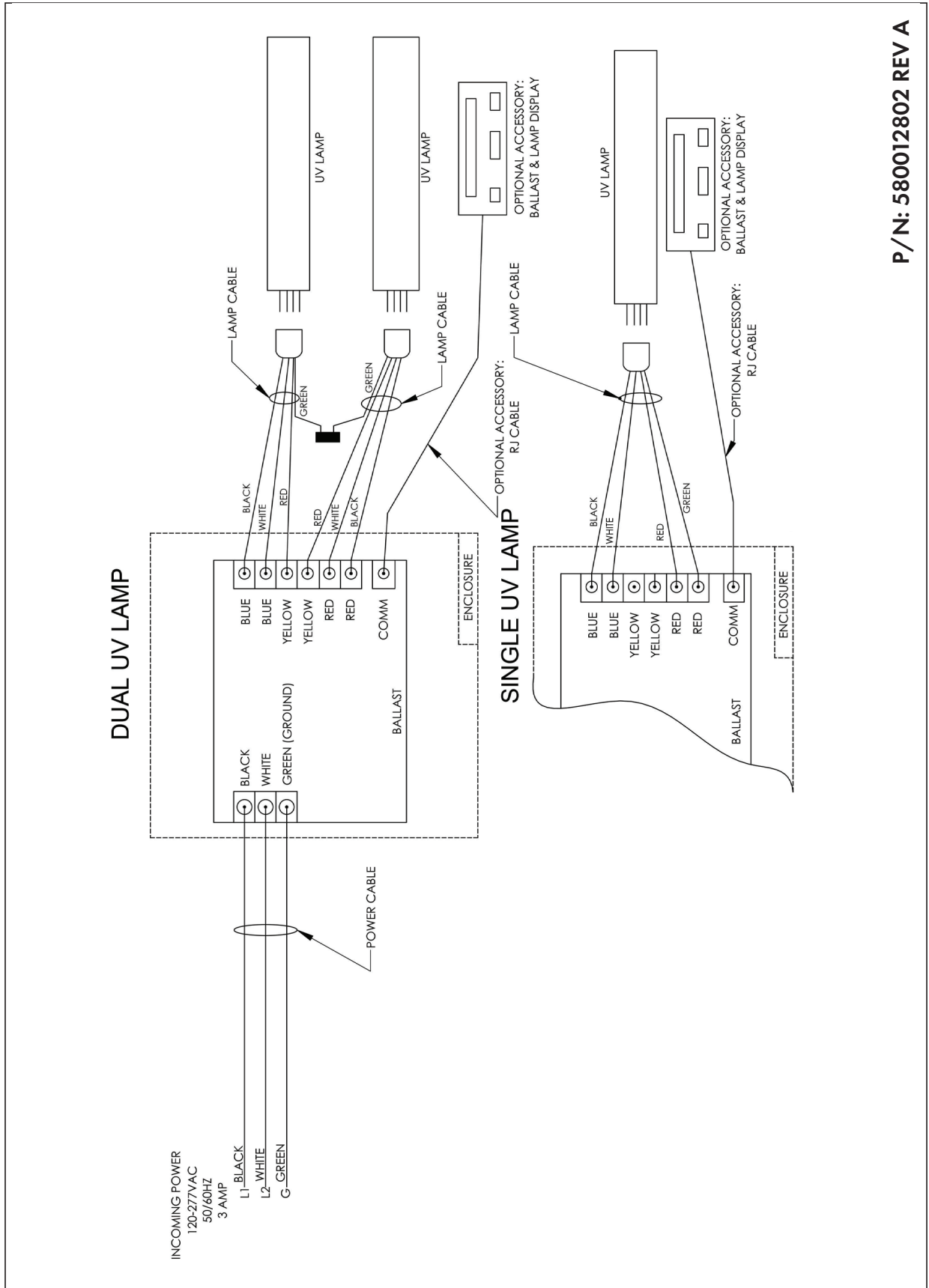

P/N: 580012802 REV A

Diagram 2: Electrical Wiring Schematic for xUV-15xxxx Model Product



MOUNTING

Figured 7, 8, and 9 show examples of the Commercial UV series installed in Roof Top Mount HVAC system. Figures 10, 11, and 12 show examples of product installed in HVAC Ductwork. These examples are not provided to be all exclusive and limited to but to assist the installer with where and how to install this product. There are infinite other product installation orientations which can be acceptable by following the basic information and guidelines provided within this manual.

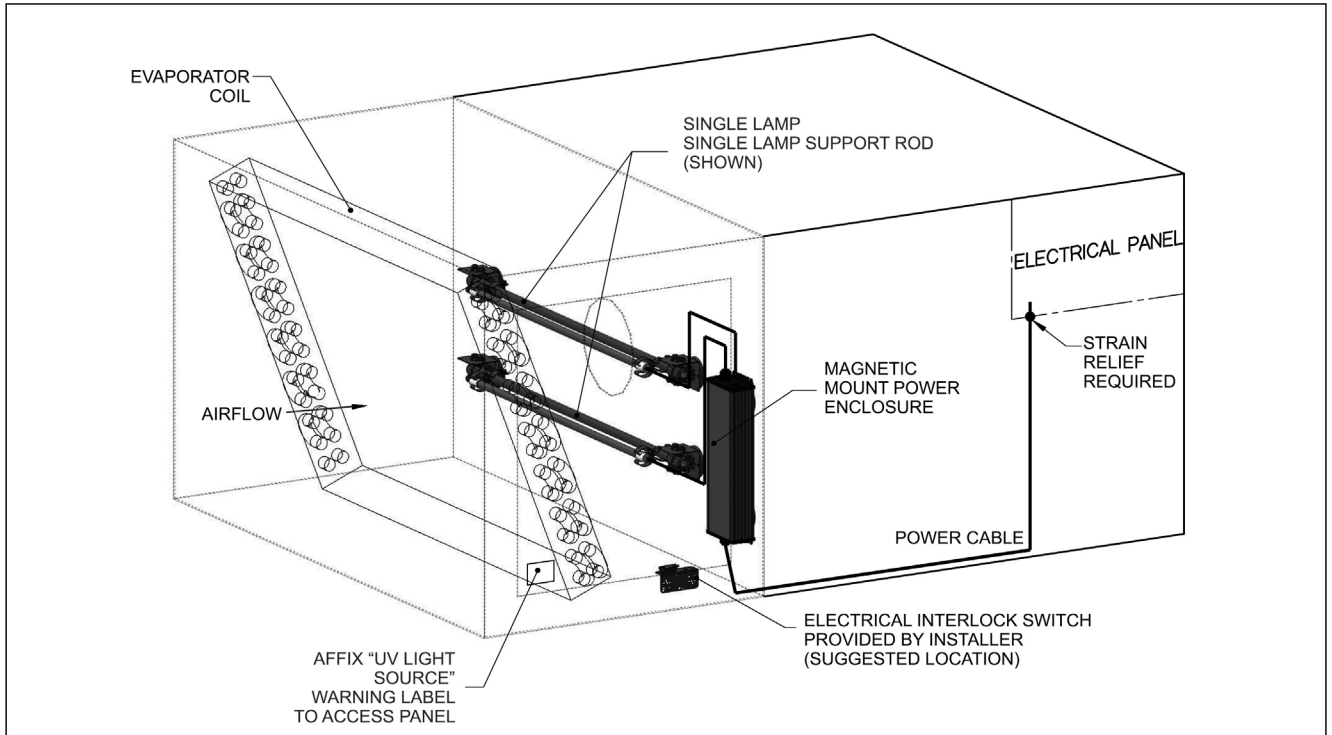

Figure 7: Generic Example of Rooftop HVAC Supply Air Side Installation

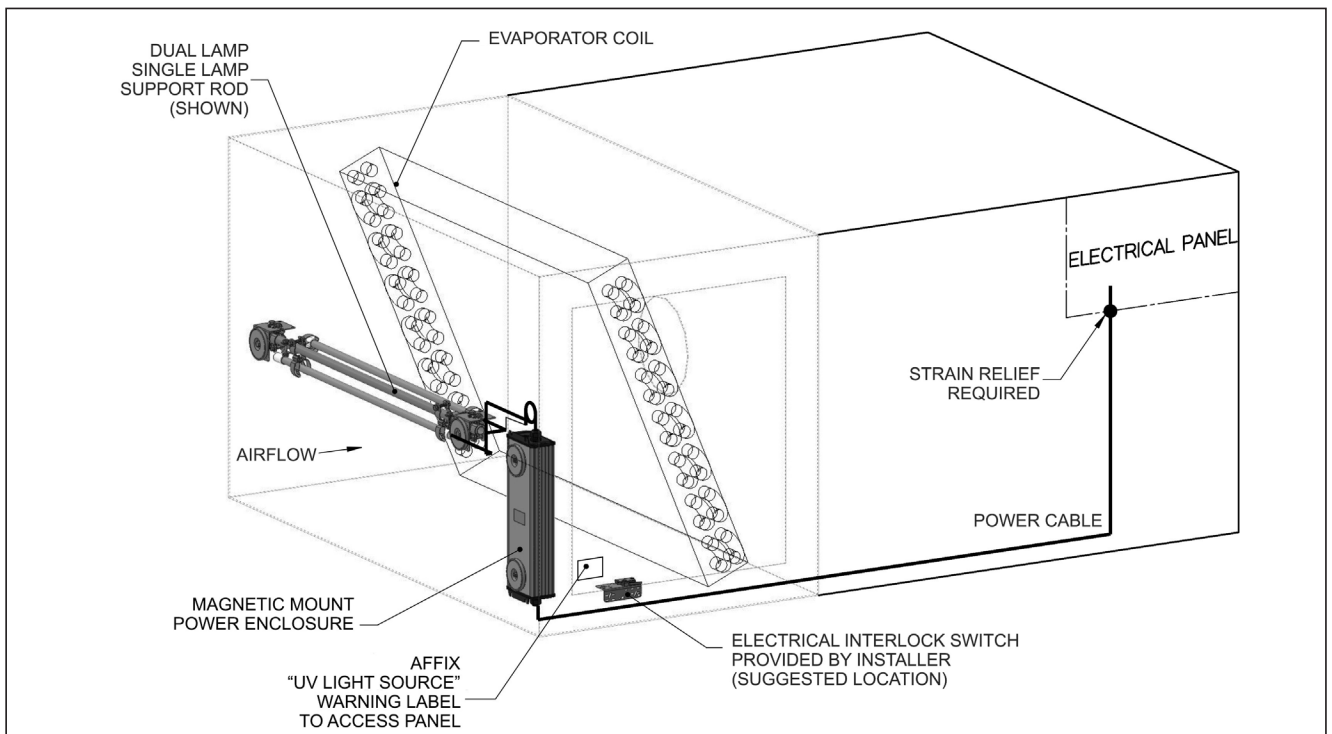

Figure 8: Generic Example of Rooftop HVAC Return Air Side Installation



MOUNTING - CONTINUED

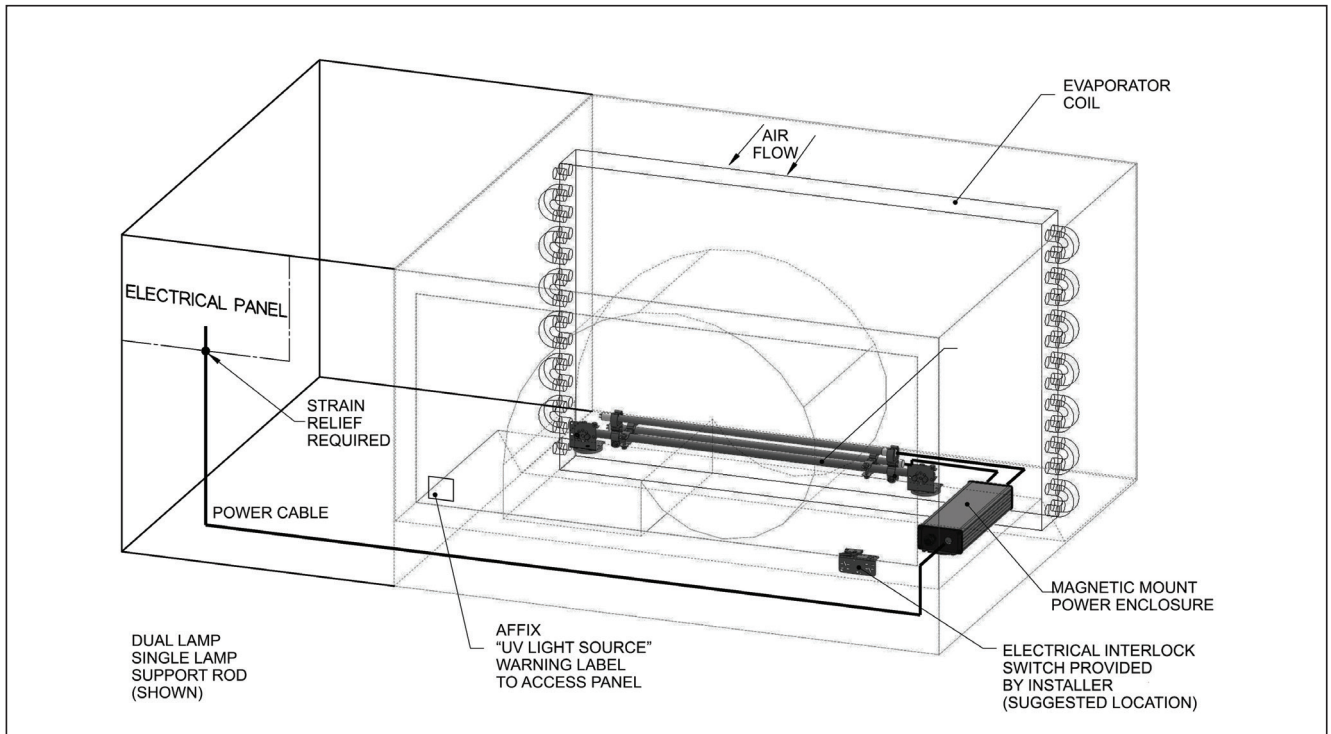

Figure 9: Generic Example of Rooftop HVAC Return Air Side Installation

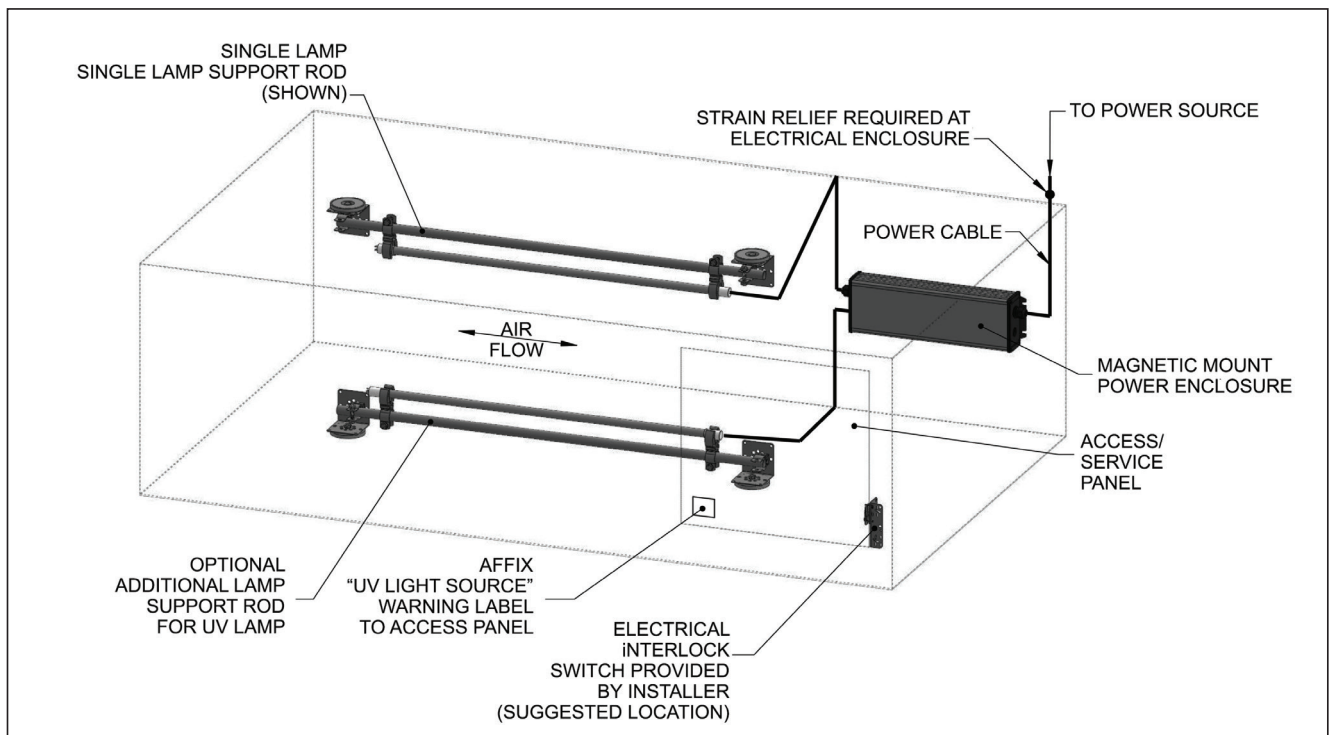

Figure 10: Generic HVAC Ductwork Installation (Horizontal Rod Support)



MOUNTING - CONTINUED

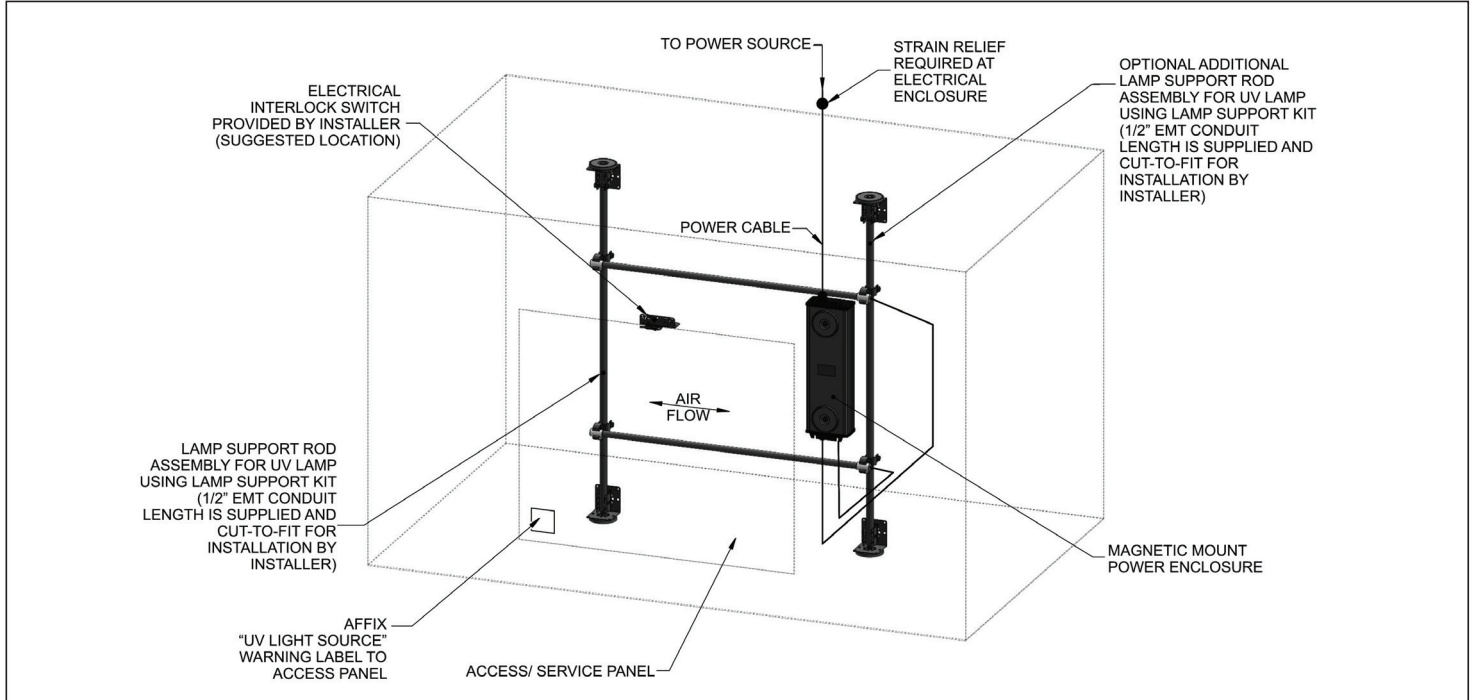

Figure 11: Generic HVAC Ducted Installation (H Style Configuration: Vertical Rod Support with Horizontal Lamp)- Requires Additional Lamp Support Kit with EMT Conduit Mounting Brackets and Inverted U-Shaped Brackets Installed in Alternative Rotated Orientation for Installation.

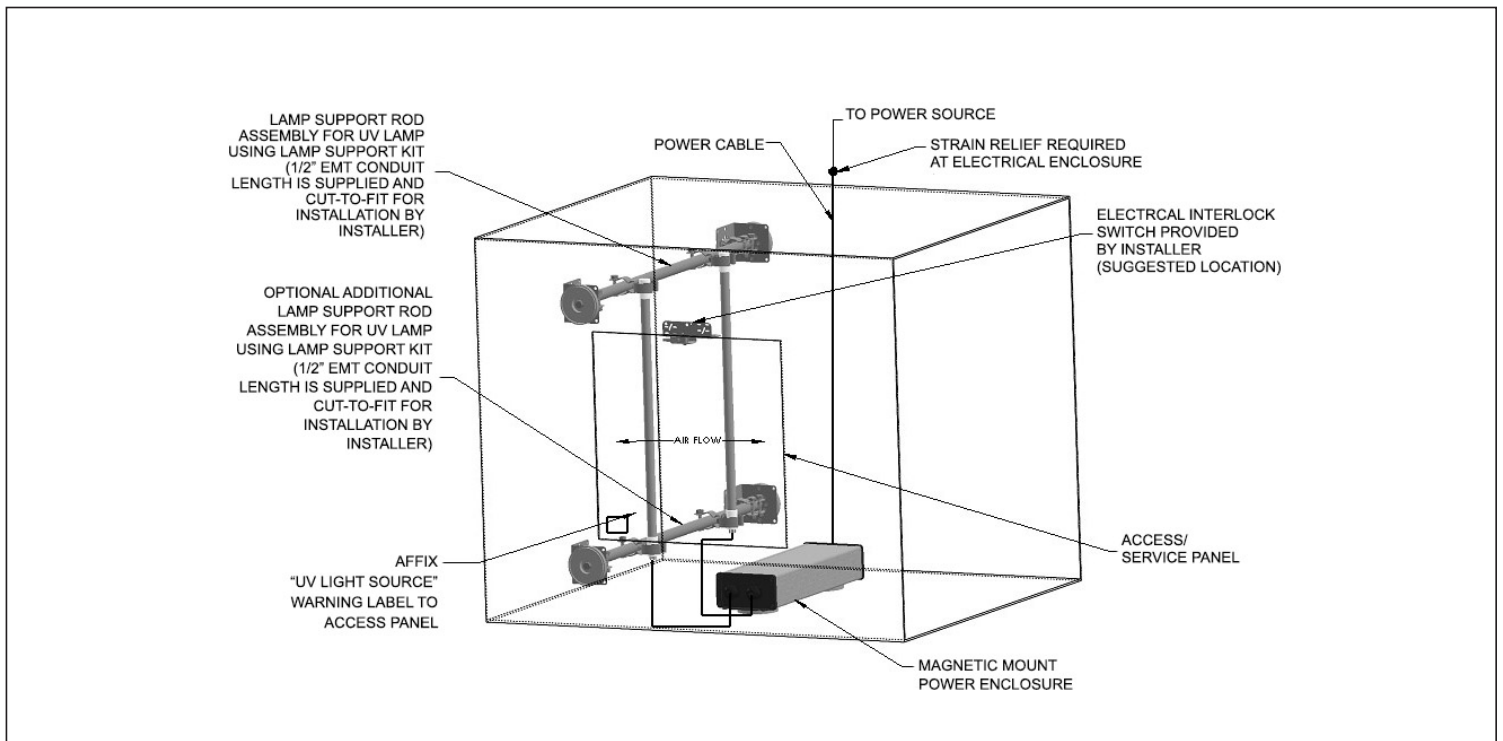

Figure 12: Generic HVAC Ducted Installation (H Style Rod Configuration requires rotated end mounted conduit brackets and rotated U-Shaped lamp support brackets).

CAUTION: When UV lamps are installed in a vertical orientation, as shown in Figure 12, the cable connection point to the lamps should be at the lowest point of the lamp (ie: do not orient lamps to be plugged in from the top).



MOUNTING - CONTINUED

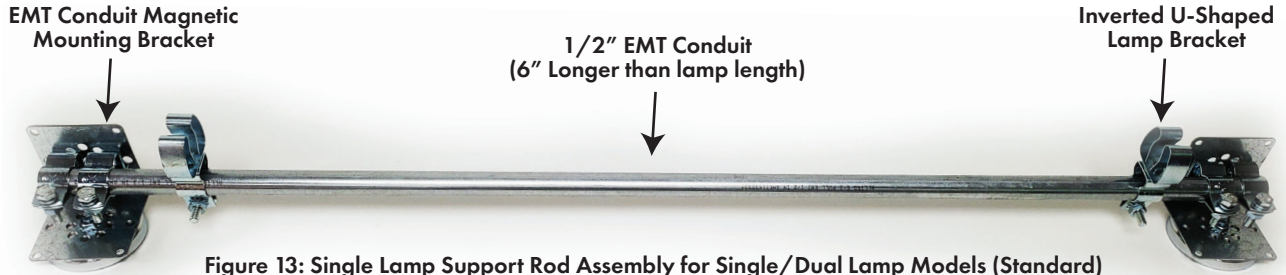

Figure 13: Single Lamp Support Rod Assembly for Single/Dual Lamp Models (Standard)

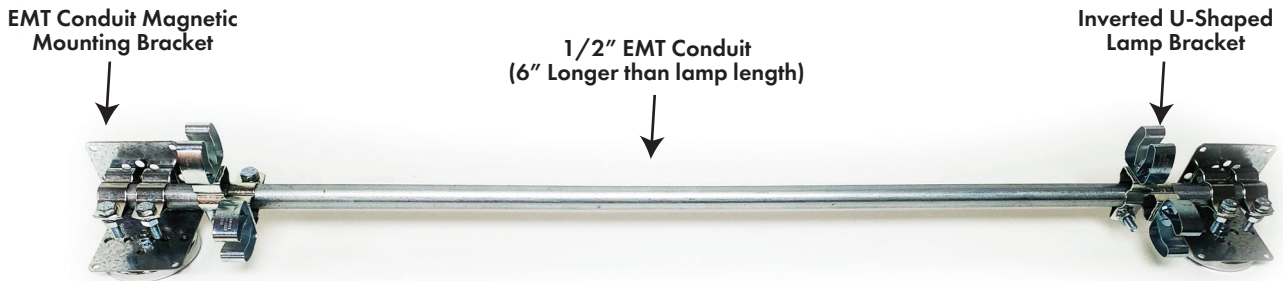

Figure 14: Dual Lamp Support Rod Assembly for Dual Lamp Models (Optional)

OPTIONAL LAMP AND 1/2" EMT CONDUIT MOUNTING ACCESSORIES

The following optional mounting accessories are sold separately to assist installation process.

DESCRIPTION	PART NUMBER	PHOTO
Tri Magnet, Infinite 180°, Rod Support Bracket, Qty 2	602611303	
Tri-Foor Magnet, 45° Dual, Rod Support Bracket, Qty 2	602611302	
Tri-Foot Magnet Base Bracket, Qty 2	602611304	
Single Magnet, 90° Dual, Rode Support Bracket, Qty 2	602611301	
Single Magnet, Lamp Support Bracket, Qty 2	602611305	
1/2" Conduit/Lamp Support Bracket, Qty 2	602611306	



MOUNTING - CONTINUED

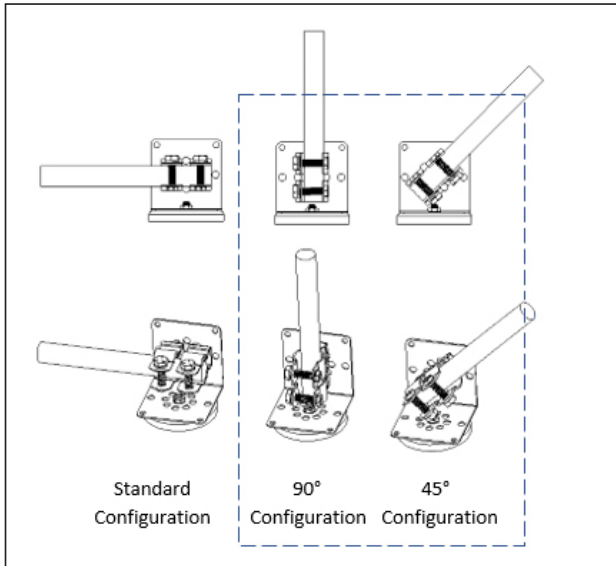

Figure 15: EMT Conduit Bracket Assembly for 18" thru 34" UV Lamp Lengths

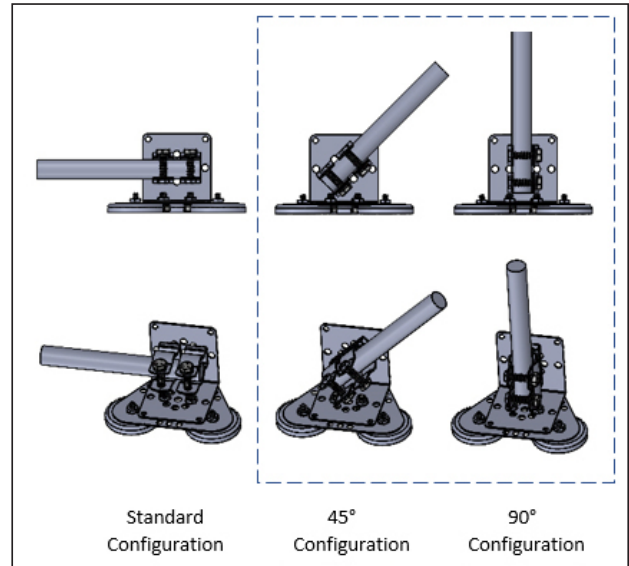

Figure 16: EMT Tri-Foot Magnet Conduit Bracket Assembly for 38" thru 58" UV Lamp Lengths

Standard Configuration for EMT Conduit Bracket Assembly is what is supplied from factory for all rod assemblies with UVC lamp lengths of 18" thru 34" in length. Bracket hardware can be reconfigured to form 45° and 90° bracket configurations. (See Figure 15)

Standard configuration for EMT Tri-foot Magnet Conduit Bracket Assembly is what is supplied from factory for all rod assemblies with UVC lamp lengths of 38" thru 58" in length. Bracket hardware can be reconfigured to form 45° and 90° bracket configurations. The EMT Tri-Foot Magnet Conduit Bracket Assembly is shipped with bottom tri-foot plate with magnets separate from the L-Bracket for packaging reasons. Refer to Figure 20 for how to assemble tri-foot Magnet plate with magnets to L-Bracket assembly. (See Figure 16)

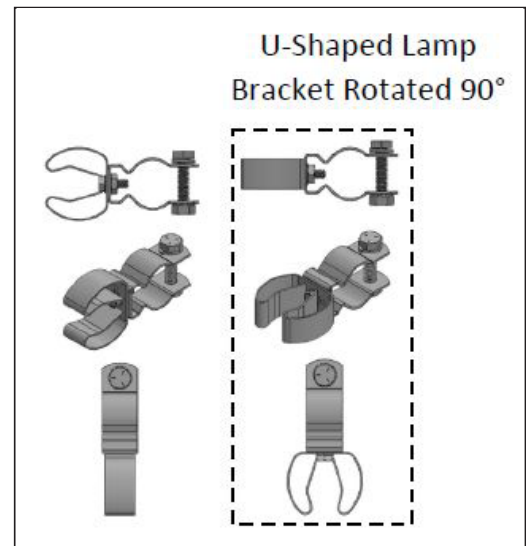

Figure 17: Inverted U-Shaped Lamp Support Bracket - Left Side View (Standard Assembly)

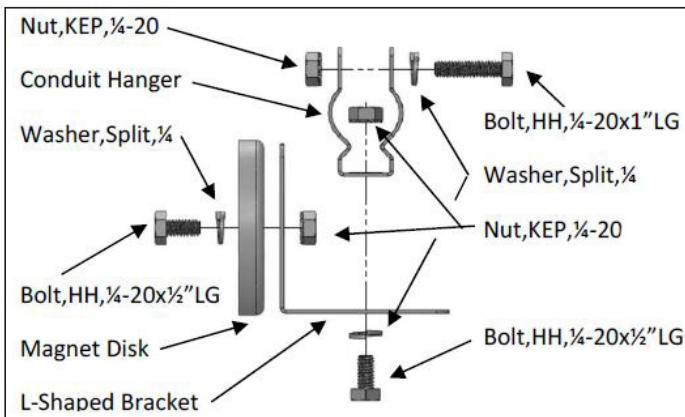

Figure 18: EMT Conduit Bracket Assembly (Exploded View)

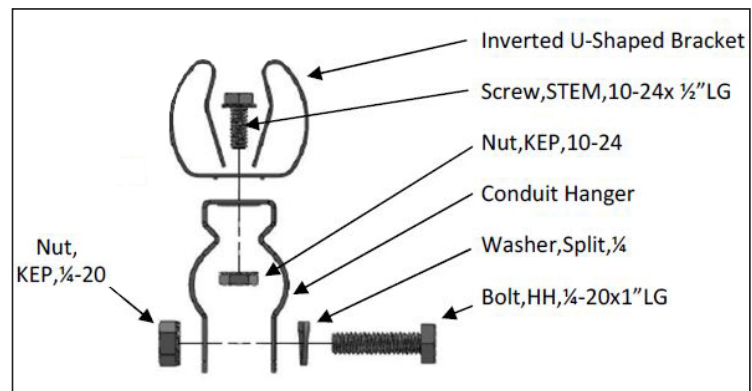

Figure 19: Inverted U-Shaped Lamp Support Bracket (Exploded View)



MOUNTING - CONTINUED

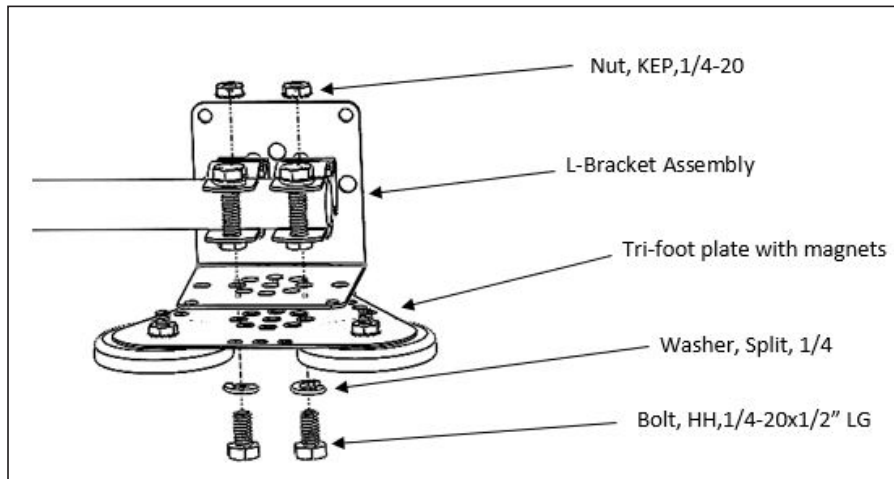

Figure 20: EMT Tri-Foot Partial Assembly (Exploded View)

OUTDOOR MOUNTING KIT

When installing Magnetic Mount Power Enclosure outdoors, order the Outdoor Mounting Kit (refer to Figure 21). The outdoor mounting kit is an optional accessory kit designed to protect the lamp cables from accidental damage and provides a bracket to securely mount the Magnetic Mount Power Enclosure. This kit comes with: a formed mounting bracket, lamp cable cover plate, two panel pass-thru cable connectors, hardware and mounting instruction sheet.

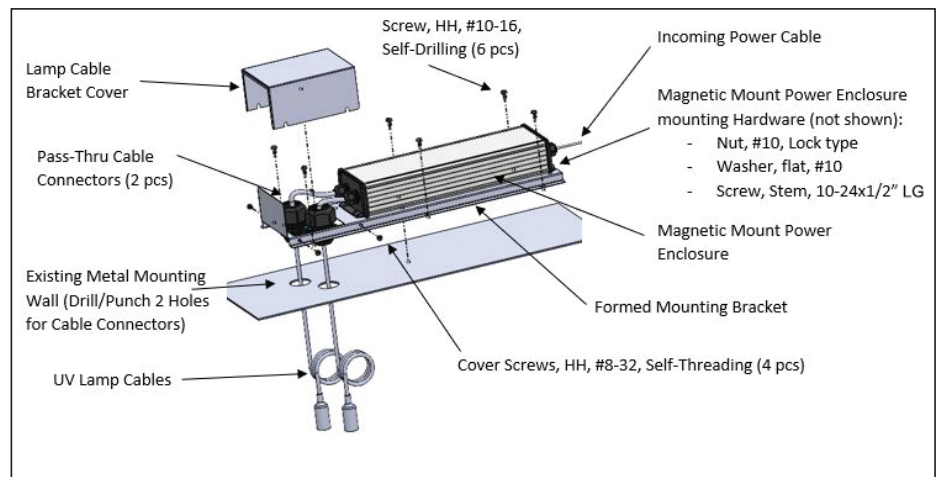

Figure 21: Outdoor Mounting Kit

OPTIONAL LAMP SHIELDS

Optional Lamp Shield can be added to lamp support rod assemblies to shield some areas from UVC rays and direct the UV intensity towards a specific area as shown in Figure 22. The lamp shield is designed to mount between Inverted U-shaped bracket (which holds UV lamp) and EMT conduit bracket.

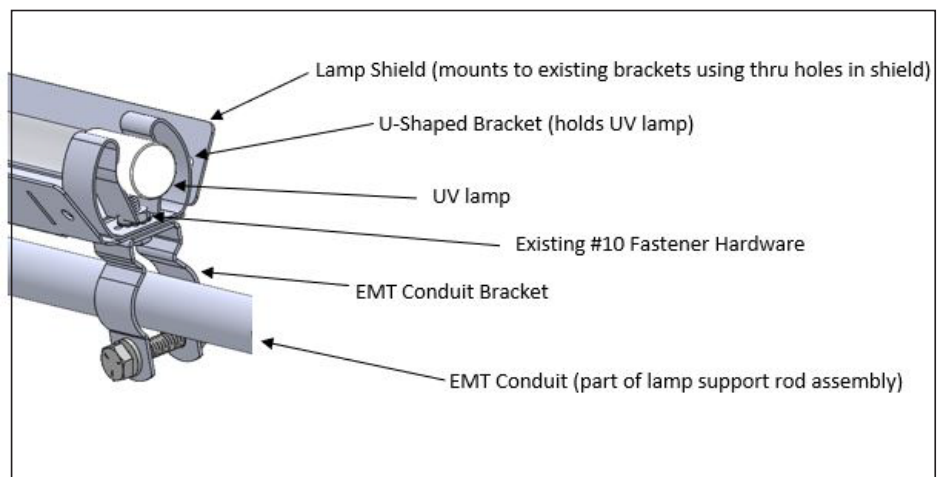

Figure 22: Generic Lamp Shield Installation



OPTIONAL STATUS DISPLAY MODULE

The optional Status Display Module kit is available for xUV-15xxxx models only and provides a multi-purpose interface with the operational conditions of UV-Aire System. The display module can be used to interface with building automation control and maintenance network systems. Refer to the status display module manual included with optional accessory for specific information on installing, configuring, and operation of the module. The status display module kit consists of: a display module, interconnecting cable, end plate with cable connector and instruction manual.

The display module must be installed in a dry and protected location. The display module must be located within a 12-foot distance from the magnetic power enclosure.



Figure 23: Optional Status Display Module

INSTALLATION STEPS

WARNING: Before installing or servicing UV system, always turn all power OFF to HVAC system and have appliance unplugged/de-energized. Electrical shock can cause personal injury or death. Never expose eyes or skin to direct UVC light from any source.

AVERTISSEMENT: Avant d'installer ou d'entretenir un système UV, éteignez toujours toute la tension du système CVC et débranchez et mettez l'appareil hors tension. Les chocs électriques peuvent causer des blessures corporelles ou la mort. N'exposez jamais les yeux ou la peau à la lumière UVC directe de quelque source que ce soit.

1. Select location and mount"
 - A. Magnetic Mount Power Enclosure
 - B. Lamp Support Rod(s) - [without UV lamps installed]
 - C. Electrical Interlock Switch to access/service panel. Switch to be provided by installer.
2. Affix "UV Light Source" Warning Label to outer surface of access panel/service panel.
3. Route and connect main power cable to electrical panel. Install strain relief device/connector for power cable to electrical panel. Install and wire electrical interlock switch in main power circuit. Refer to wiring diagrams 1 & 2 for electrical power requirements.
4. Install UV lamp(s) on lamp support rod(s) inverted U-Shaped brackets. Clean lamp glass surfaces as necessary using cleaning pad provided.
5. Connect UV lamp cable(s) to lamps (reference Figures 4A and 4B).
6. Secure all cables using tie wraps and add foil tape, as necessary.
7. Verify all fastener hardware is tight after installation.
8. Apply power to UV system:
 - A. Close Electrical Interlock Switch and verify UV lamp(s) lite up.
 - B. Fill-in Date on UV Lamp Installation Label and affix lamp label to installation.
9. Install Electrical Interlock panel/service panel.



MAINTENANCE

WARNING: Disconnect power to appliance before commencing with inspection, cleaning, and/or part replacement.

AVERTISSEMENT: Coupez l'appareil d'alimentation avant de commencer l'inspection, le nettoyage et/ou le remplacement de la pièce.

CAUTION: Wear disposable, non-absorbent protective gloves prior to inspection and/or lamp replacement in case of accidental breakage of lamp glass.

LA PRUDENCE: Portez des gants de protection jetables et non absorbants avant l'inspection et/ou le remplacement de la lampe en cas de bris accidentel du verre de la lampe.

INSPECTION PROCEDURE

Remove Access Panel to:

1. Inspect all cables for breakdown and wire fraying
2. Inspect Lamp Support Rod
 - A. Verify hardware is not loose
 - B. Verify lamps are secured in place over plastic/ceramic section with inverted U-shaped bracket.
3. Verify power enclosure is secured in place and no visual damage.
4. Verify access panel switch assembly is secured in place, functional, no visual damage and no loose connectors and fasteners.
5. Verify UV Light Warning Label is affixed to access panel.
6. Re-install access panel. Reconnect power appliance.
 - A. Verify from UV Lamp Installation Label that lamps are less than two years old.
 - B. Partially remove access panel to verify UV Lamps are lit up.

REPLACEMENT SCHEDULE

UV Lamps should be replaced every two years or 18,000 hours of operation.
Ballast should be replaced every five years or 50,000 hours of operation.

TROUBLESHOOTING

SYMPTOM	POSSIBLE CAUSE	CORRECTIVE ACTION
UV Lamp does not light	Power Loss	Verify Main Power. Correct as necessary
	Poor Lamp Cable Connection	Check cable connection at each lamp
	Bad Lamp	Dual lamp system requires both lamps to operate. Replace bad lamp or both lamps
	Incorrect Wiring	Inspect circuit to wiring schematic connection diagram 1
	Access Door Switch	Verify access door switch contact is NO when lever is not depressed and switch contact is NC when lever is depressed (ie: access panel is installed)
	Ballast Bad	Replace ballast inside of enclosure
Visibly Weak UV Lamp	Poor Lamp Cable Connection	Check cable connection at each lamp
	Lamp at End of Life	Replace UV Lamp
	Lamp Cold	If lamp is at or below 36°F, Lamp is too cold to operate properly. Turn up heat in ductwork/HVAC unit and recheck
Magnetic Lamp Rod or Magnetic Power Enclosure Sliding Downward	Metal surface dirty or too much vibration.	Install screws into magnetic lamp rod or power enclosure endplate flanges to secure in place



REPLACEMENT PARTS

PART NUMBER	MODEL	DESCRIPTION	USED ON MODEL(S)
602610617	CUVL-18N	17.5" UVC Lamp Non-Coated (1)	xUV-1118xN
602610623	CUVL-23N	23" UVC Lamp Non-Coated (1)	xUV-1123xN
602610628	CUVL-28N	28" UVC Lamp Non-Coated (1)	xUV-1128xN
602610634	CUVL-34N	34" UVC Lamp Non-Coated (1)	xUV-1134xN
602610638	CUVL-38N	38" UVC Lamp Non-Coated (1)	xUV-1538xN
602610646	CUVL-46N	46" UVC Lamp Non-Coated (1)	xUV-1546xN
602610658	CUVL-58N	58" UVC Lamp Non-Coated (1)	xUV-1558xN
602610723	CUVL-23C	23" UVC Lamp FEP Coated (1)	xUV-1123xC
602610728	CUVL-28C	28" UVC Lamp FEP Coated (1)	xUV-1128xC
602610734	CUVL-34C	34" UVC Lamp FEP Coated (1)	xUV-1134xC
602610738	CUVL-38C	38" UVC Lamp FEP Coated (1)	xUV-1538xC
602610746	CUVL-46C	46" UVC Lamp FEP Coated (1)	xUV-1546xC
602610758	CUVL-58C	58" UVC Lamp FEP Coated (1)	xUV-1558xC
602610800	CUV-INTLCK	Electronic Interlock Switch	All Models
602611011	SHS11	Ballast (40-95W)	xUV-11xxxx
602611015	SHS15	Ballast (32-190W)	xUV-15xxxx
602610500	CUV-RIM	Remote Interface Kit	xUV-15xxxx
602611101	DUV-SC	3 Ft. Nominal Lamp Cable	DUV-xxxxxx
602611102	CUV-LC	12 Ft. Nominal Lamp Cable	CUV-xxxxxx
602611103	CUV-PC	9 Ft. Nominal Power Cable	All Models
602611104	CUV-DC	12 Ft. Nominal CUV-RIM Display Cable	xUV-15xxxxxx
602611105	CUV-DISP	Display Only Replacement	xUV-15xxxxxx
620177500	CUV-OMK	Outdoor Mounting Kit	All Models
602610918	CUV-SHIELD18	UV Shield for 17.5" CUV Lamp	xUV-1118xx
602610923	CUV-SHIELD23	UV Shield for 23" CUV Lamp	xUV-1123xx
602610928	CUV-SHIELD28	UV Shield for 28" CUV Lamp	xUV-1128xx
602610934	CUV-SHIELD34	UV Shield for 34" CUV Lamp	xUV-1134xx
602610938	CUV-SHEILD38	UV Shield for 38" CUV Lamp	xUV-1538xx
602610946	CUV-SHIELD46	UV Shield for 46" CUV Lamp	xUV-1546xx
602610958	CUV-SHIELD58	UV Shield for 58" CUV Lamp	xUV-1558xx
602611301	CUV-SMR	Single Magnet Conduit Support Bracket (2)	All Models
602611302	CUV-TMR	Tri-Magnet Conduit Support Bracket (2)	All Models
602611303	CUV-TMI	Tri-Magnet, Infinite 180° Support Bracket (2)	All Models
602611304	CUV-TMB	Tri-Foot Magnet Replacement Base (2)	All Models
602611305	CUV-SMB	Single Magnet Lamp Support Bracket	All Models
602611306	CUV-CLB	Conduit/Lamp Support Bracket (2)	All Models

Denotes:

(1) Replacement lamp kits contain two lamps

(2) Kits contain parts to build two assemblies

This manual may be downloaded and printed from the Field Controls website (www.fieldcontrols.com)

WARRANTY

For warranty information about this or any Field Controls product, visit:
www.fieldcontrols.com/ventCool

Field Controls Technical Support
1.800.742.8368
fieldtec@fieldcontrols.com



FIELDCONTROLS

Phone: 252.522.3031 • Fax: 252.522.0214
www.fieldcontrols.com